

# CAPACITIVE LEVEL CONTROLS SC - SCD SERIES



## WORKING PRINCIPLE

The principle is based on the behaviour of a capacitor the capacitance of which depends on the area of the armatures in the vicinity, the distances between them and the dielectric constant of the material.

In the case of a capacitive level control the armatures of the capacitor are represented by the walls of the tank on one side and by the electrode of a probe, isolated from the walls on the other.

As the surfaces of the electrode and the walls of the tank remain constant the only variable is the material which acts as the dielectric. The dielectric constant relative to air or vacuum is 1, whilst by definition that of any other material is greater than 1, therefore by varying the quantity of material in the tank the capacitance of the capacitor is varied and this is measured by applying to the electrodes a high frequency alternating voltage and as the capacitance increases as a result in the increasing level in the tank the current flowing in the capacitor also increases.

This value of frequency current is transformed by the control circuit into a current which is used to indicate the level.

## APPLICATIONS

Capacitive level controls are widely used where it is necessary to control with a good safety margin of intervention the level of substances both liquid and solid which may not be conductive.

They are particularly used in silos for cereals, foodstuffs, seeds, biscuit plants and the food industry in general.

They are also used in the transport, dosing, stocking and handling of plastic materials, petrochemical products, in foundries and cement factories.

The field of use is vast and is practically anywhere where it is necessary to control the level inside tanks which contain many types of different material.

## SENSITIVITY ADJUSTMENT

After having installed the probe, if the tank is not conductive, carry out the earthing of the probe by connecting to the connector placed on the probe. In order to calibrate the sensitivity the adjustment potentiometer should be adjusted with the probe free from material until the point at which the relay switches is found and this should be noted on the potentiometer. The probe should then be immersed in the material to be controlled and the potentiometer should be adjusted once again until the relay switches, once again note the position. As a last operation place the position of the potentiometer in the mid position between the two markings. Both the SC model with incorporated power supply and the SCD model with separate power supply are supplied with a min/max level security switch which can be positioned depending on the control function that is to be carried out.

## LIMITATIONS

When using capacitive probes it should be borne in mind that large deposits adhering to the probe may affect the measurement, this can however, be discounted in most cases as the probe is covered in teflon.

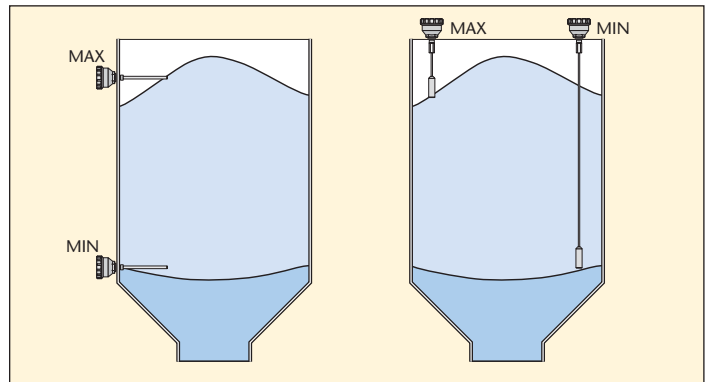

The value of the dielectric constant of the material must not be too low, it must in any case differ significantly from 1, furthermore it is important to bear in mind the composition of the material, humidity content, temperature etc.

## SENSITIVITY ADJUSTMENT AND CONNECTION DIAGRAM

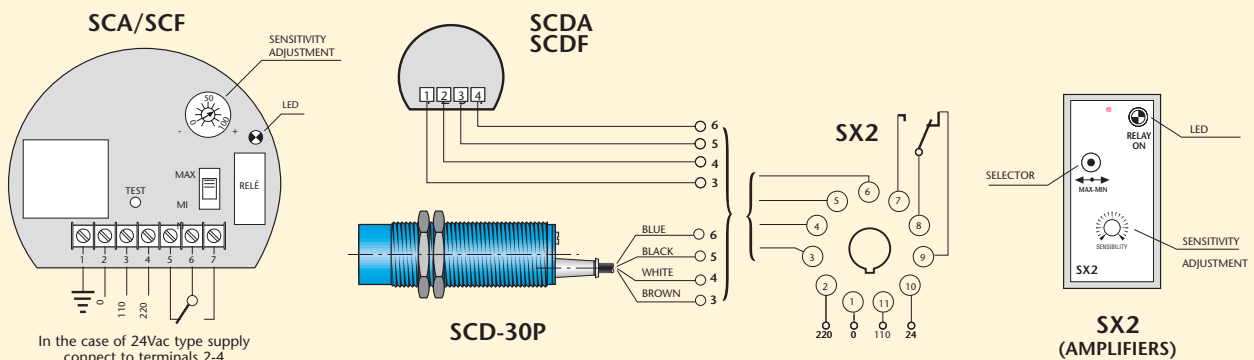

# CAPACITIVE LEVEL CONTROLS SC - SCD SERIES



## SCA - SCF TYPES

This is the compact version which has both the mechanical and electronic parts in one unit.

They are supplied with bar electrodes of teflon coated steel (SCA) with standard lengths of 300 - 500 - 800 mm, or with cable electrodes which are of plastified steel and tensioning, weight covered in teflon (SCF) with standard lengths of 1.000 - 2.000 - 3.000 - 4.000 mm, these are easily shortened.

## SCDA - SCDF TYPES

These types have the electronic and mechanical parts separate. The power supply/amplifier is situated in the SX2 unit.

In this version the connection cable between the probe and the control unit can be of any length, it is recommended that this cable be kept separate from any power cables or that it be screened.

The mechanical parts are supplied as per the compact version with bar or cable probes of equal characteristics.

This system is used when it is necessary to have the calibration and the visualisation of operation in one control panel.

## SCD30P TYPES

This minituarised version presents itself as a capacitive sensor but it works in conjunction with the SX2 unit. It is used when it is necessary to have the calibration and the visualisation of operation in one control panel and where the small dimensions of the sensing unit over come space problems.

## MECHANICAL CHARACTERISTICS OF THE PROBES

The body of the SC and SCD probes is an aluminium casting with two cable clamps on the outputs, standard fixing 1 1/2" GAS, available also 1" or 2" GAS. The body has a degree of protection of IP 65 which allows for outside installation.

The body of the SCD30P is of macrolon plastic and can be used in combination with the SCM protection housing (Page 65)



## ELECTRICAL CHARACTERISTICS

Supply voltage $\pm 15\%$	24Vca-110/220Vca 50 $\pm$ 60Hz
On request power supply	24Vcc (Not SX2)
Temperature limits type SC	-20 $\pm$ +60°C
Temperature limits type SCD / SCD-30P	-20 $\pm$ +100°C
Temperature limits type SX2	-20 $\pm$ +60°C
Maximum absorption	2,5VA
Output with 1 pole changeover	5A a 220Vca
Degree of protection type SC / SCD	IP65
Degree of protection type SCD-30P	IP67
Maximum tank pressure	12 Kg./cmq.

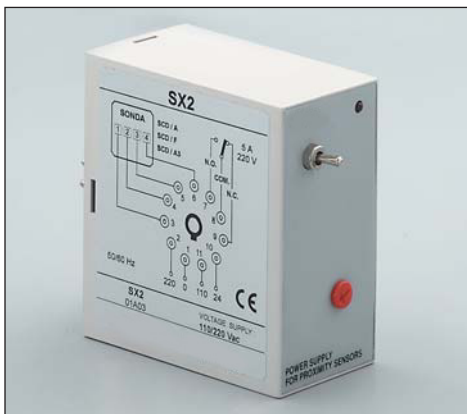

## DIMENSIONS (mm)

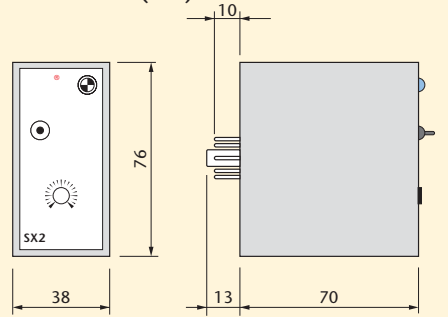

## DIMENSIONS (mm)

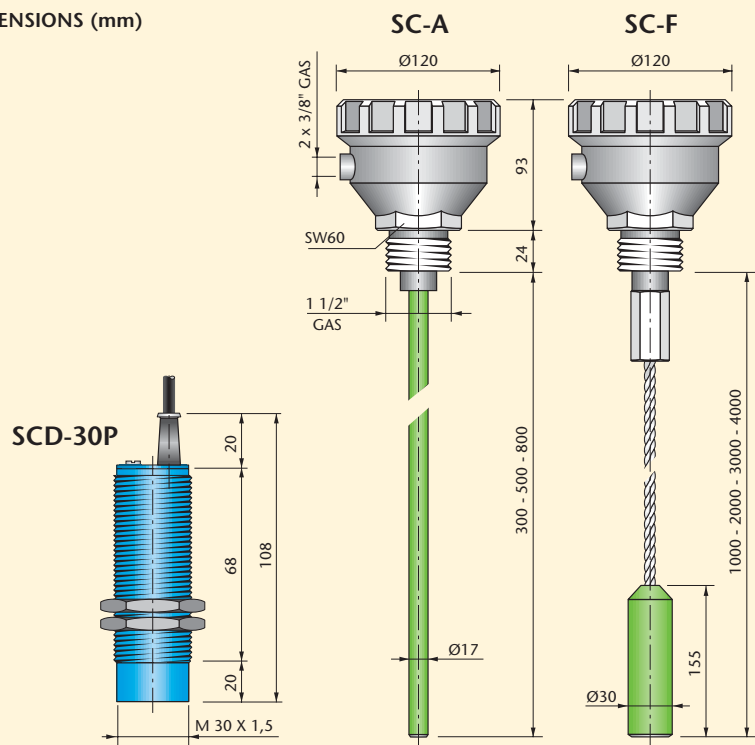

# MECHANICAL LEVEL CONTROL FOR SOLIDS SE-A



## GENERAL DESCRIPTION

They are used for the level control in containers holding product in powder or granule form. The body is of cast aluminium with a cable gland at the output and a stainless steel shaft mounted on sealed roller bearings, the paddle is aluminium.

The functioning is based on the slow rotation of a 3 watt synchronous motor which turns the paddle which is placed in the container. In the absence of material the paddle turns, material coming into contact with the paddle causes a breaking effect which slows down the motor and in turn causes the unit to switch.

A second switch switches off the power of the motor.

The paddle starts to rotate again when the material in the container falls freeing the paddle.

## MOUNTING

The unit is placed on the external wall of the container fixing it by means of the 6 hole flange.

The material must be able to move freely around the paddle and this must not be installed in the jet of material.

In order to avoid this it may be necessary to install deflectors above the unit when the mass of the material is high.

## WIRING DIAGRAMS

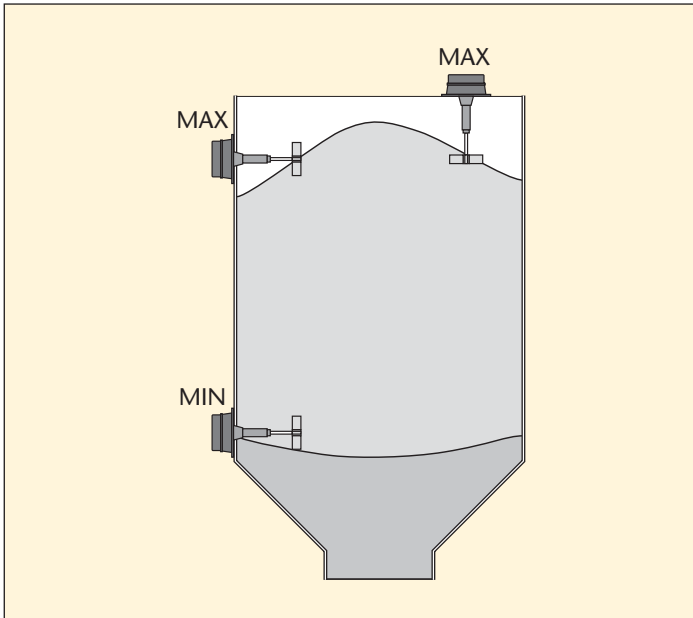
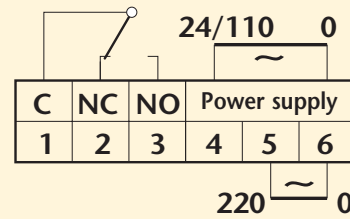

## DIMENSIONS (mm)

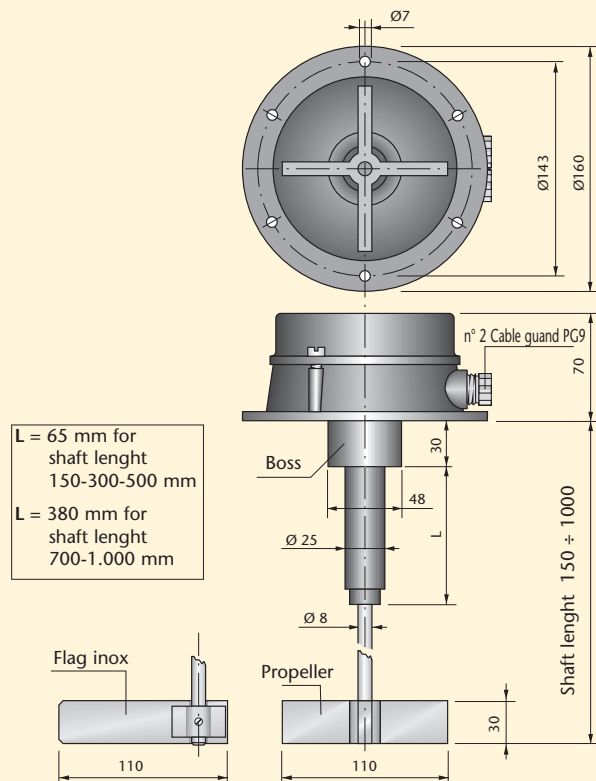

## TECHNICAL CHARACTERISTICS

Power supply	24-48-110-220Vac ± 10%
Absorption	3VA
Electrical contact	6A a 250V
Temperature limits	-10 ÷ +60 °C
Degree of protection	IP 55
Shaft length	150-300-500-700-1000 mm.

N.B.: the force to be applied for stopping the shaft rotation corresponds to 1 kilo with standard paddle.

# MEMBRANE LEVEL CONTROL FOR SOLIDS SM-85



## GENERAL DESCRIPTION

This unit is suitable for controlling the maximum and minimum levels. In silos and tanks containing materials such as powder, granule, such as rice, cereals, plastic material, coffee, sand, etc.

Its functioning is due to the pressure created by a product on the rubber membrane which activates a fast acting microswitch.

The sensitivity of the switching can be adjusted by means of a screw placed on the lid of the unit, adjustment is made depending on the material to be sensed as a function of its specific weight.

Variations in humidity and temperature do not compromise the functioning, furthermore the membrane is resistant to blows and vibrations.

## MOUNTING

The unit must be assembled on the external wall of silos or tanks by means of the three holes situated on the fixing flanges and by making a hole of 86 mm diameter in the container so as to allow contact with the material.

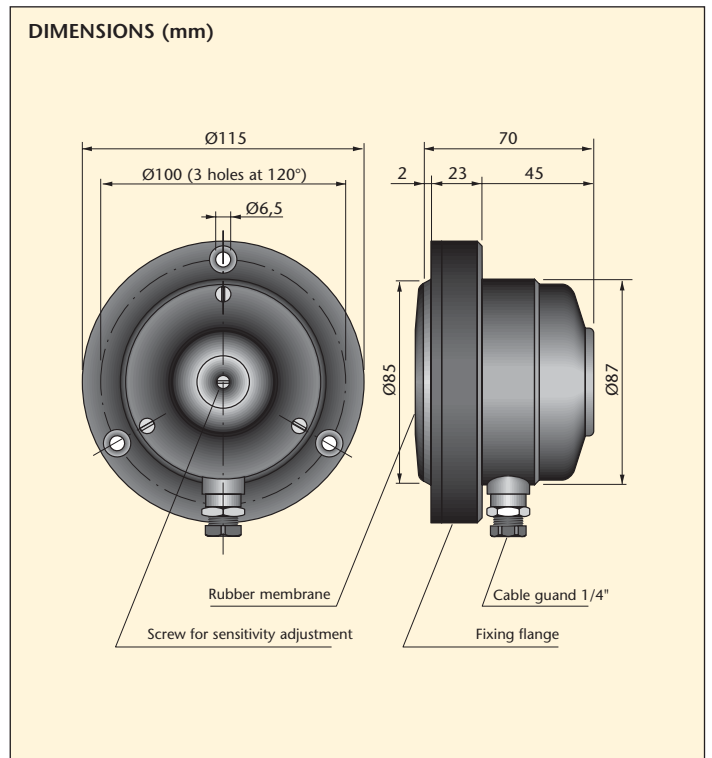
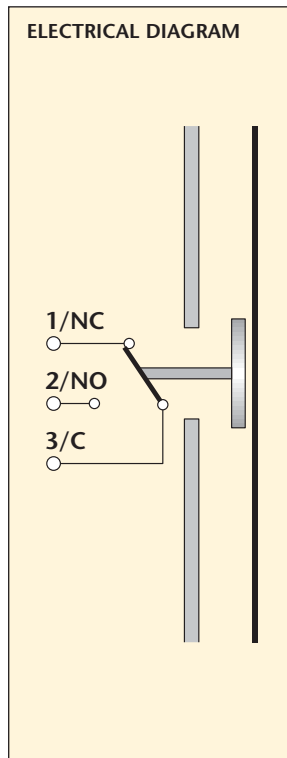
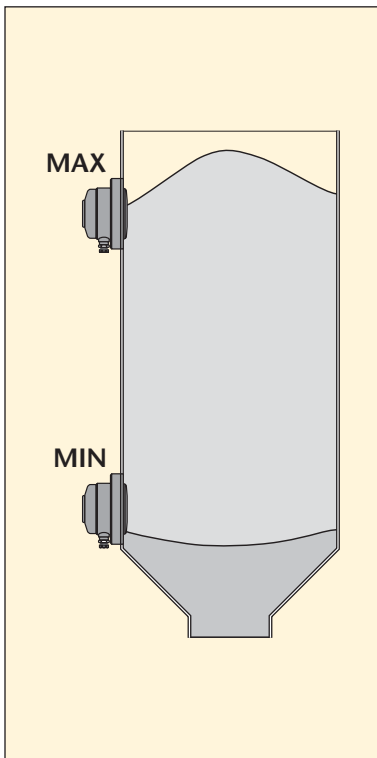

LEVEL CONTROLS

## TECHNICAL CHARACTERISTICS

Plastic housing	Autoextinguishing ABS
Fixing flange	Aluminium
Membrane	Neoprene 82 mm. dia.
Electrical contacts	6A at 250V
Temperature limits	-10 ÷ +60 °C
Degree of protection	IP 55
Response sensitivity:	Min. 50 gr central, 20 mm. water pressure on membrane

# CONDUCTIVITY LEVEL CONTROL FOR LIQUIDS CL1001-CL1002 SERIES



## WORKING PRINCIPLE

The CL 1001 - CL 1002 level controls work on the resistivity of liquids and sense the level via the electrodes placed in the conductive liquids. The presence of liquid between the electrode (or electrodes) and the metal surface of the container (or earth electrode) causes the functioning of the electronic circuit in the control unit and the subsequent commutation of the output relay.

It is also possible to sense solids as long as the conductivity of the material is within the range of the unit which in its standard form reaches 40 KOhm.

Other models which can sense materials with a resistivity up to 1 MOhm are available on request. The low alternating voltage and current applied to the electrodes and the isolation level between them guarantees a safe operation.

They are used as level controls in tanks, heaters deep wells and other containers and as alarm units for overfilling, presence or absence in any position and the checking of ice accumulation.

The unit is supplied in single voltage form with an octal base and is interchangeable with most of the units available on the market. It can also be supplied in a multivoltage version with undecal base.

**Type CL1001/O:** Single voltage level control with power supply at 24Vac, or 110Vac, or 220Vac supplied with octal base. It is the most economic type of this series.

**Type CL1001/U:** Multi voltage level control either at 110Vac, or 220Vac, by changing the wiring diagram. It is supplied with undecal base it is also available at 24Vac single voltage.

**Type CL1002/U:** Single voltage level control available with power supply at 24Vac or 110Vac or 220Vac, it is supplied with undecal base and relay output with 2 pole changeover 5A at 220Vac.

**R5 ANTI-WAVE DELAY:** On request it is possible to delay for 5 sec. (non-adjustment) so the wave created by the liquid does not cause commutation.

**RANGE OF SENSITIVITY:** All type are supplied with sensitivity adjustment and are also available with special sensitivity, see table below.

## TECHNICAL CHARACTERISTICS

Supply voltage type CL1001/O	24-110-220V 50-60Hz
Supply voltage type CL1001/U	24-110/220V 50-60Hz
Supply voltage type CL1002/U	24-110-220V 50-60Hz
Voltage limits	± 15%
Voltage between the electrodes	12Vac
Absorption	3.5VA
Relay output with 1 pole changeover	5 A a 220 Vac
Relay output with 2 pole changeover	5 A a 220 Vac
Temperature limits	- 20 + 60°C
Degree of protection	IP40
Sensitivity adjustment	2÷40 KOhm (On request higher)
LED	relay ON-OFF

## SPECIAL SENSITIVITY

200 ohm ÷ 10 Kohm
2 Kohm ÷ 40 Kohm
10 Kohm ÷ 200 Kohm
10 Kohm ÷ 500 Kohm
10 Kohm ÷ 1000 Kohm

## REFERENCE FOR ORDERING

10 K
40 K (standard)
200 k
500 k
1000 K

## IDENTIFICATION REFERENCE

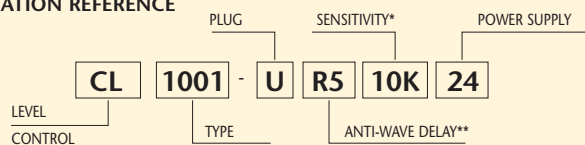

\* Specify only if different from the standard \*\* Specify only if requested.

## DIMENSIONS (mm)

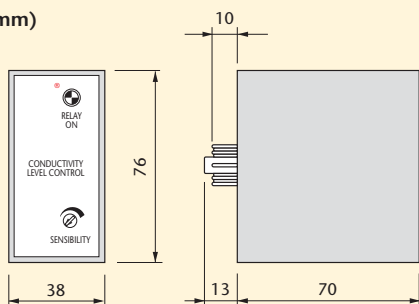

## WIRING DIAGRAMS

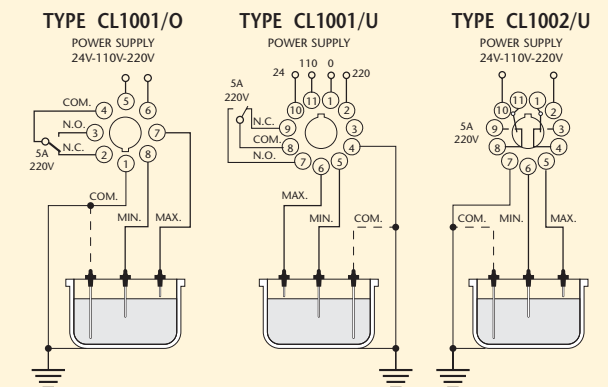

### ONE LEVEL CONTROL

Use a reference probe or the tank earthing and a level probe. (To be connected to the terminal that corresponds to the max. level). When the liquid leaves the probe level max. the relay switches in order to permit the tank to be filled. (Use output contact N.C. of relay).

### TWO LEVEL CONTROL (Filling)

Use a reference probe or the tank earthing, min. level probe and max. level probe. Tank filling begins the liquid leaves the minimum probe and switches off when the max. probe is reached. (Use output contact N.C. of relay).

### TWO LEVEL CONTROL (To empty)

Use a reference probe or the tank earthing, min. level probe and max. level probe. The emptying begins when the liquid reaches the max. probe and switches off when the liquid abandons the min. probe. (Use output contact N.O. of relay).

# ELECTRODE HOLDER FOR CONDUCTIVITY LEVEL CONTROL



## SPECIFICATIONS

These units are supplied with electrodes which are suitable for the sensing of conductive liquids, to be used with level controls CL1001 and CL1002.

They consist of a stainless steel electrode support or plastic material and a separate electrode which can be supplied with different length according to the different requirements.

### ONE POLE DETECTOR TYPE CL/1N

This one pole detector is used for level controls of wells or tanks.

It consists of a stainless steel electrode AISI316, a polycarbonate electrode holder and a cable gland. The sealing ring placed on the lower part and gland prevents the liquid from entering into contact with the cable connection causing subsequent oxidization.

### ONE POLE DETECTOR TYPE CL-A

This one pole detector is used for level controls in boilers, autoclaves in all conditions where there are pressure (12 kg/cm<sup>2</sup>) and high temperatures (max. 200°C).

It consists of a stainless steel holder AISI 316 with a rubber cap of protection, insulating material of teflon and stainless steel electrode support AISI 316.

### TWO POLE DETECTOR TYPE CLK-A

The electrode holder is provided with a three pole connector for the electrical connection, two poles are connected to the electrode and the third, earth pole, is connected to the thread stainless steel holder. Using this method if the tank is in metallic material it is not necessary to install a earthing probe simplifying the wiring diagrams. It consists of a stainless steel holder AISI 316, provided with connector, supported by a teflon coated element and electrode holder AISI 316.

Max. working pressure: 12 kgs cm<sup>2</sup> and max. temperature at 100°C limited by the presence of the connector in plastic material.

### THREE POLE DETECTOR TYPE CL3-A

The electrode holder is thermosetting plastic material with terminal block cover and three nickelled brass holders with M6 plug for electrode 6 mm dia.



(these are not included).

It is supplied with adapter to be used with standard electrode 4 mm dia. It is suitable for temperature up to 130°C and non-pressure application. On request a metallic bracket is available for flange fixing to electrode holder (type FCL3).

## ELECTRODES

They are supplied with five different length: 100, 300, 500, 700, 1000 mm, 4 mm dia., stainless steel AISI 316. They can be used together with CL-A, CLK-A and CL3-A with special adapter.

When ordering add "E" to the length required (e.i. E-100 = 100 mm length).

## DIMENSIONS (mm)

CL/1N

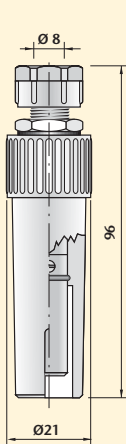

CL-A

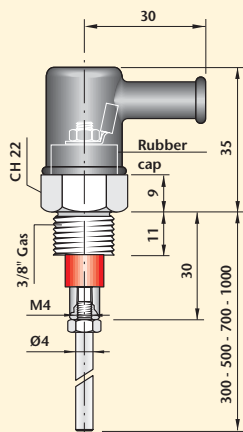

CLK-A

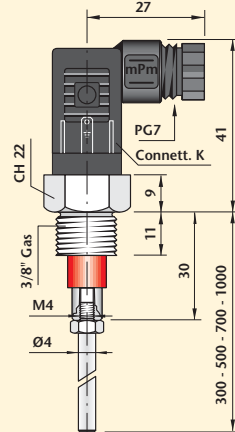

CL3-A

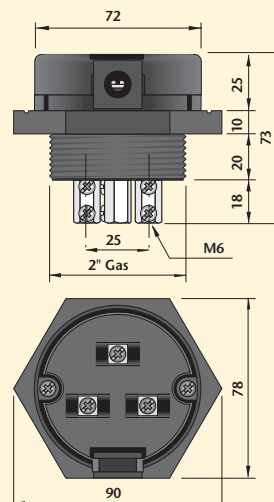

FCL-3

