

NAMUR INDUCTIVE SENSORS



RING HOUSING SIA05 - SIA12 - SIA15 - SIA22 - SIA30 - SIA44 - SIA63 - SIA100
2 WIRES D.C. - VERSION N

- NOT EMBEDDABLE (NON FLUSH MOUNTING)

TECHNICAL CHARACTERISTICS

Dimensions mm

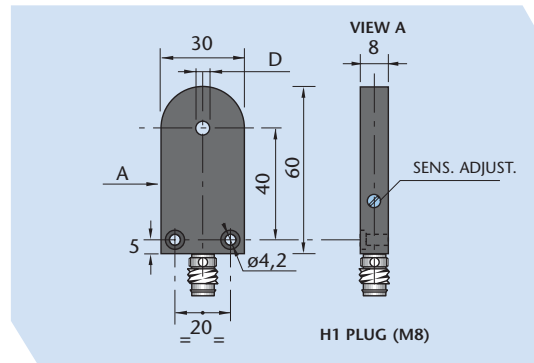
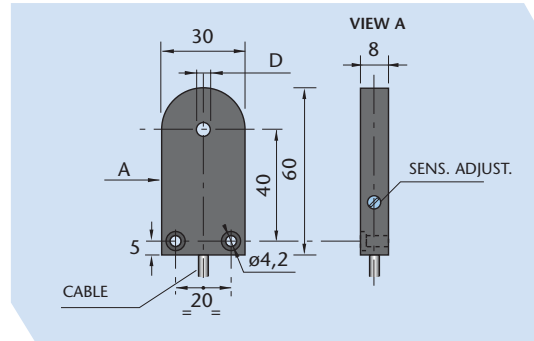

MODELS WITH CABLE	SIA 05 - NE	SIA 12 - NE	SIA 15 - NE
MODELS WITH CONNECTOR	SIA 05 - NE H1	SIA 12 - NE H1	SIA 15 - NE H1
Hole diameter (D) mm	5	12	15
Continuous voltage (residual ripple ≤10%) V	8,2 ("5 ÷ 30" see note 1 at page 6)		
Absorption current at 8.2V mA	In presence of metal ≤ 1 mA - In absence of metal ≥ 3 mA		
Switching frequency (min-max) Hz	600 ÷ 1500	600 ÷ 1000	600 ÷ 1000
Repeatability % of Sn	< 0.3		
Temperature limits °C	-20 ÷ +60		
Degree of protection IP	IP 65		
Housing	Plastic		
Cable PUR blue m	2 x 0.25 mm ²		
Connector plug	H1	H1	H1

NAMUR DIN 19234 - EEx ia IIC T4 - NAMUR DIN 19234 - EEx ia IIC T4 - NAMUR DIN 19234 - EEx ia IIC T4 - NAMUR DIN 19234 - EEx ia IIC T4 -

SPECIFICATIONS	MIN. DIMENSIONS OF THE OBJECT (Fe37) TO DETECT	PLUG H1 - H OUTPUT POSITION VIEW	SENSITIVITY ADJUSTMENT																											
<p>In ring sensors, the sensing is carried out inside the ring. The sensor intervenes when a metallic object is introduced. They are particularly suitable for checking the presence and counting of small metal objects, screws, nuts washers etc. or for any similar operation. Also useful in verifying breakage of metal wires that pass through the ring. The ring sensor's housing is in plastic and electrical attachments can be made by means of a cable or M8 and M12 connectors depending on the model type.</p>	<table border="1"> <thead> <tr> <th>Model</th> <th>Length mm</th> <th>Diameter mm</th> </tr> </thead> <tbody> <tr><td>SIA05</td><td>1</td><td>0.7</td></tr> <tr><td>SIA12</td><td>2</td><td>1.2</td></tr> <tr><td>SIA15</td><td>2</td><td>1.2</td></tr> <tr><td>SIA22</td><td>6</td><td>3</td></tr> <tr><td>SIA30</td><td>7</td><td>4</td></tr> <tr><td>SIA44</td><td>9</td><td>5</td></tr> <tr><td>SIA63</td><td>12</td><td>6</td></tr> <tr><td>SIA100</td><td>20</td><td>12</td></tr> </tbody> </table>	Model	Length mm	Diameter mm	SIA05	1	0.7	SIA12	2	1.2	SIA15	2	1.2	SIA22	6	3	SIA30	7	4	SIA44	9	5	SIA63	12	6	SIA100	20	12		
	Model	Length mm	Diameter mm																											
	SIA05	1	0.7																											
	SIA12	2	1.2																											
	SIA15	2	1.2																											
	SIA22	6	3																											
	SIA30	7	4																											
	SIA44	9	5																											
SIA63	12	6																												
SIA100	20	12																												

Meyer Industrie-Electronic GmbH - MEYLE

Carl-Bosch-Straße 8
49525 Lengerich/Germany
Internet: www.meyle.de

Tel.: (+49) 05481/9385-0
Fax: (+49) 05481/9385-12
E-Mail: sales@meyle.de

NAMUR INDUCTIVE SENSORS



CONFORMING TO NAMUR STANDARDS (DIN 19234)
APPROVAL **EEx ia IIC T4***

INDUCTIVE

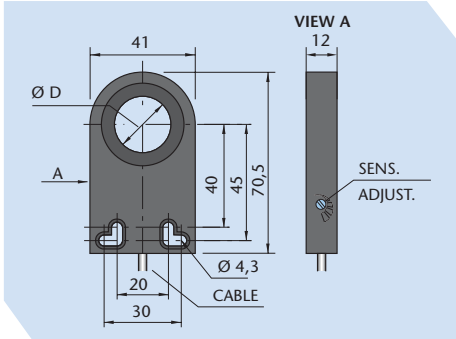

SIA 22 - NE

SIA 30 - NE

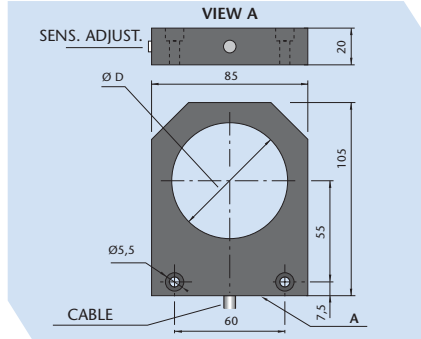

SIA 44 - NE

SIA 63 - NE

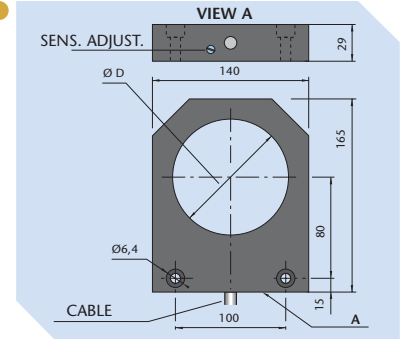

SIA 100 - NE

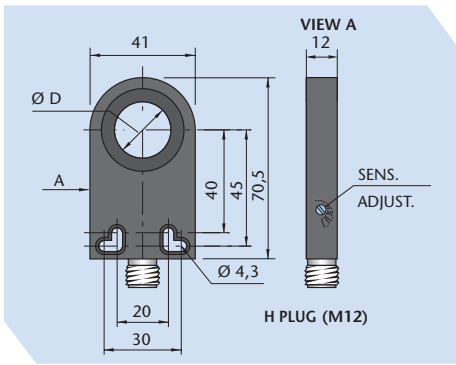

SIA 22 - NE H

SIA 30 - NE H

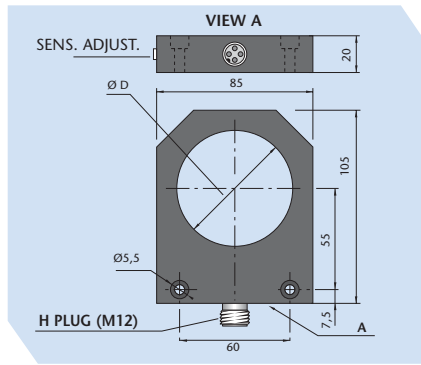

SIA 44 - NE H

SIA 63 - NE H

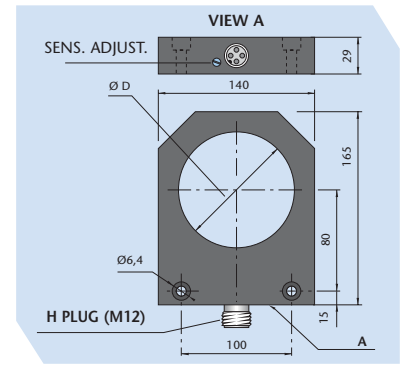

SIA 100 - NE H

8,2 ("5 ÷ 30" see note 1 at page 6)

In presence of metal ≤ 1 mA - In absence of metal ≥ 3 mA

600 ÷ 1000

600 ÷ 800

250 ÷ 600

100 ÷ 200

100

< 0.3

-20 ÷ +60

IP 65

Plastic

2 x 0.25 mm²

2 x 0.50 mm²

H

H

H

H

H

- NAMUR DIN 19234 - EEx ia IIC T4 - NAMUR DIN 19234 - EEx ia IIC T4 - NAMUR DIN 19234 - EEx ia IIC T4 - NAMUR DIN 19234 - EEx ia IIC T4 -

SELECTION OF RING SENSOR

Selection should be made based on the minimum hole diameter required.

In this way the sensitivity adjustment can be made within normal parameters and need not be pushed to the maximum risking the proper functioning of the unit.

USE WITH A DELAYED AMPLIFIERS

All types of ring sensor can work in combination with a delayed amplifier of the programmable ALTP series or ALNC series which ensures the sensing of small objects in rapid movement.

SENSITIVITY ADJUSTMENT

After having followed the instructions regarding the choice of the most suitable unit it is recommended that the sensitivity adjustment be carried out when the sensor is installed in the final position taking into account how much metal mass is close by which could alter its functioning. The sensitivity increases turning the trimmer clockwise.

EFFECTS OF METAL IN THE CLOSE VICINITY

If a moving metal part is close to the sensing area the functioning can be disturbed.

In order to avoid this, install the units some distance from metallic objects. Ensure that this does not interfere with the functioning. When applying to a metal surface make sure not to apply too close to ring hole otherwise sensor may not function correctly.

USE OF SENSOR

A distance equal to the width of the sensor should be left between each object that passes through the sensor. If more than one sensor is to be installed in close vicinity, the minimum distance indicated between sensors should be maintained as per chart indications.

INSTRUCTIONS FOR CORRECT INSTALLATION

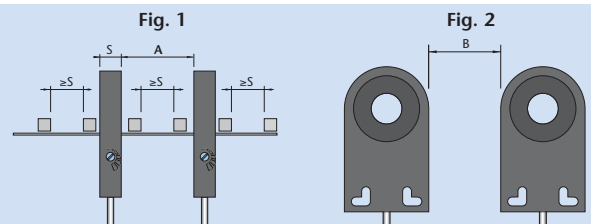

Model	SIA05	SIA12	SIA15	SIA22	SIA30	SIA44	SIA63	SIA100
A (Fig. 1) mm	25	30	30	60	60	300	300	600
B (Fig. 2) mm	10	10	10	20	20	250	250	650

* See page 7 - Applications