

# MEMBRANE LEVEL CONTROL FOR SOLIDS SM-85



## GENERAL DESCRIPTION

This unit is suitable for controlling the maximum and minimum levels. In silos and tanks containing materials such as powder, granule, such as rice, cereals, plastic material, coffee, sand, etc.

Its functioning is due to the pressure created by a product on the rubber membrane which activates a fast acting microswitch.

The sensitivity of the switching can be adjusted by means of a screw placed on the lid of the unit, adjustment is made depending on the material to be sensed as a function of its specific weight.

Variations in humidity and temperature do not compromise the functioning, furthermore the membrane is resistant to blows and vibrations.

## MOUNTING

The unit must be assembled on the external wall of silos or tanks by means of the three holes situated on the fixing flanges and by making a hole of 86 mm diameter in the container so as to allow contact with the material.

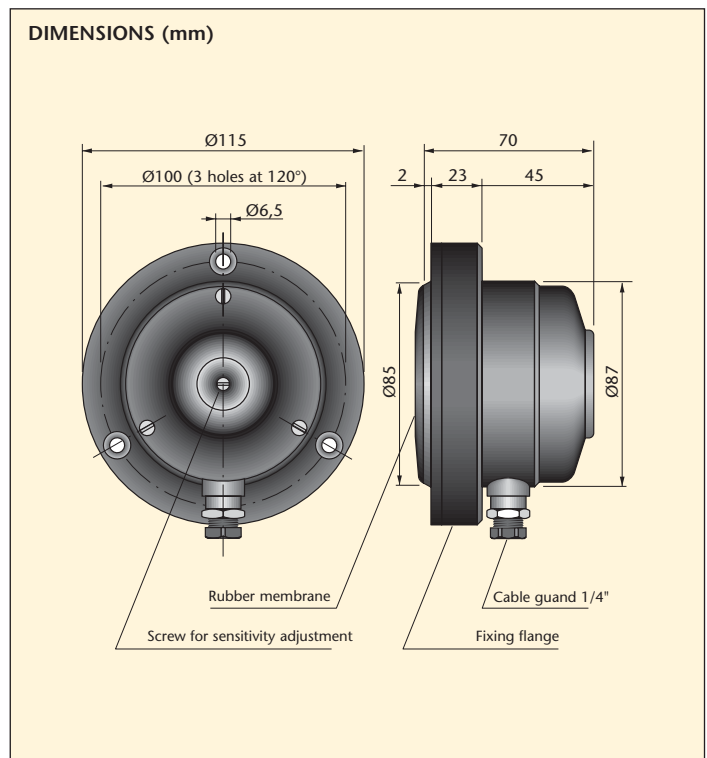
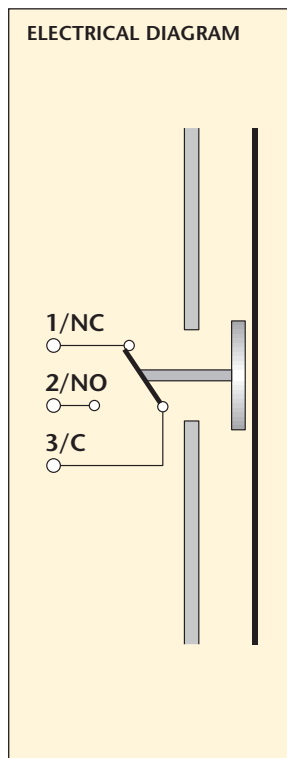
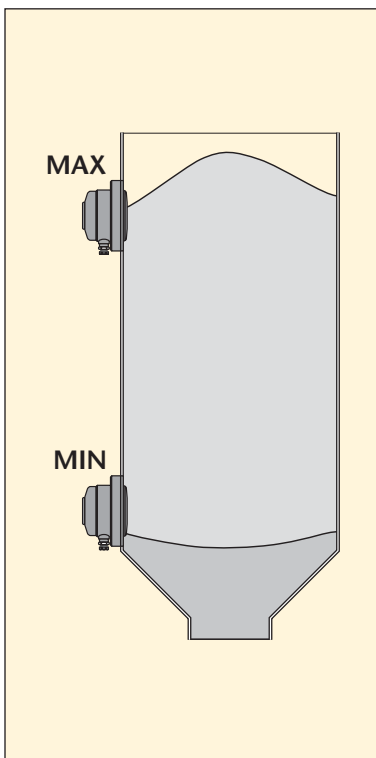

LEVEL CONTROLS

## TECHNICAL CHARACTERISTICS

Plastic housing	Autoextinguishing ABS
Fixing flange	Aluminium
Membrane	Neoprene 82 mm. dia.
Electrical contacts	6A at 250V
Temperature limits	-10 ÷ +60 °C
Degree of protection	IP 55
Response sensitivity:	Min. 50 gr central, 20 mm. water pressure on membrane

**Meyer Industrie-Electronic GmbH - MEYLE**

Carl-Bosch-Straße 8  
49525 Lengerich/Germany  
Internet: www.meyle.de

Tel.: (+49) 05481/9385-0  
Fax: (+49) 05481/9385-12  
E-Mail: sales@meyle.de