

PHOTOELECTRIC SENSORS SERIES FT



WORKING PRINCIPLE

These electronic devices, photoelectric sensors or photocells, use the light emission principle combined with the electronic and are made up of an emitter or luminous source, the light rays of which are detected by a receiver. The variation in luminous signal, obtained when interrupting this ray, is converted into an electrical signal and is measured and used by an electrical circuit. The light used is either infrared or red. By making use of this light various type of photoelectric sensors can be made.

The MEYLE photoelectric sensors available in the FOTOSTAR range are the FT18M - FT18 -FTQ series in direct reflection, with reflector with polarized light and emitter-receiver versions. Due to their flexibility regarding the various standard programmable versions these products offer the possibility of stocking reduction and are easily interchangeable with most of the units available on the market. They are used in the field of automation to check for the presence, counting, position control, etc., and they are compatible with most logic programmers.

TYPE OF FUNCTION

DIRECT REFLECTION (P TYPE)

In this type of function the emitter of the infrared light and the receiver are close together. The sensing is obtained by the reflection of the rays from the object. In the use of these photocells it is important to bear in mind the colour and the type of surface of the object. With opaque surfaces the sensing distance is affected by the colour of the object, light colours correspond to the maximum distances and vice versa. In the case of shiny objects the effect of the surface is more important than the colour. The sensing distance in the technical data is related to matt white paper.

REFLECTION WITH REFLECTOR (R TYPE)

This type also has the emitter and receiver close together.

The reflection of the light emitted is obtained by using one or more reflectors and the sensing of the object occurs when these rays are interrupted. These photocells allow longer sensing distances as the rays emitted are almost totally reflected towards the receiver.

REFLECTION WITH REFLECTOR - POLARIZED LIGHT (AR TYPE)

Similar to the R type, these photocells use an antireflex device, the use of such a device, which bases its functioning on a polarized band of light, offers considerable advantages and secure readings even when the object to be sensed has a very shiny surface. They are not in the technical data affected by random reflections.

THRU BEAM EMITTER-RECEIVER (B TYPE)

In this type of function the emitter and receiver of infra-red light face each other.

Sensing is achieved when this barrier of light is interrupted, they have a high reception as there is no dispersion between emitter and receiver.

These photocells are therefore used for large distances where a high security of functioning is required.

M18 types are supplyable with shutter of various diameters to be screwed on to optic part of both photoelectric sensors. This accessory permits detection of small objects in precision detecting applications. (Page 77)

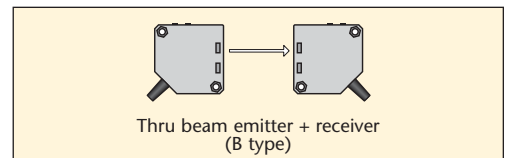
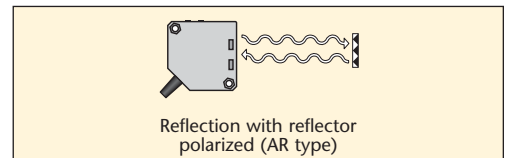
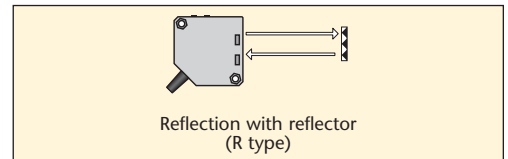
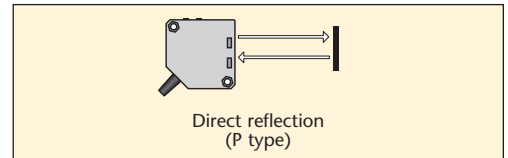

TYPES AVAILABLE

FT18M



FT18

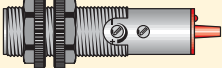

FTQ

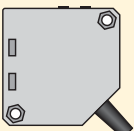

FT18M SERIES

Cylindrical construction M18x1 with housing and fixing nuts in stainless steel AISI 303. Types available in 10 ÷ 30Vdc NPN or PNP programmable and NO+NC static output, yellow led operation indicator and green led stability indicator, sensitivity adjustment incorporated. All types are available either with axial beam or 90° beam, cable exit or H plug for M12 connector.

FT18 SERIES

Cylindrical construction M18x1 with housing and fixing nuts in plastic material. These are supplied in 10 ÷ 30Vdc with characteristics similar to the FT18M series and are also available with supply voltage of 20 ÷ 250Vac with the possibility of programming NO or NC outputs. Types in direct current are only available with axial beam, cable exit without sensitivity adjustment. Types in alternating current are also avail-

able with beam 90°, H plug exit for M12 connector and sensitivity adjustment.

FTQ SERIES

Compact size in plastic housing, dimensions 50x50x18mm. Types available with supply voltage of 10 ÷ 30Vdc NPN or PNP programmable with NO+NC static output. Types available with supply voltage of 12 ÷ 240Vdc/ac (multivoltage) with relay output, programmable by means of a switch for the selection of the relay ON or OFF.

All versions are supplied with yellow led-operation indicator and green led-stability indicator and trimmer for the sensitivity adjustment.

The FTQ series is available with cable exit or moving H plug for M12 connector to select the direction of the connector exit.

All the types in direct current with static output can be connected to normal or delayed

power supplies of the ALNC-ALTP types and also to the CRTP rotation control.

INSTALLATION INDICATIONS

- MEYLE photoelectric sensors are immune to ambient light, attention should however be given to other light sources.
- In disturbed areas or areas that contain materials such as oil, powder etc., it is recommended that the barrier type separating emitter and receiver is used.
- In the use of photocells with standard reflector ensure that they are not too close together, abnormal functioning could result.
- Ensure the photocell is mechanically well fixed in order to avoid movement of the beam due to vibration.
- Attention should be given to the fixing of the connection wires keeping them separated from cables supplying motors, contactors, etc.

Meyer Industrie-Electronic GmbH - MEYLE

Carl-Bosch-Straße 8
49525 Lengerich/Germany
Internet: www.meyle.de

Tel.: (+49) 05481/9385-0
Fax: (+49) 05481/9385-12
E-Mail: sales@meyle.de

PHOTOELECTRIC SENSORS - GENERAL DETAILS



DESCRIPTION AND TECHNICAL TERMINOLOGY

SENSING DISTANCE (Sn)

It is the space in which it is possible to sense an object. In the case of direct reflection types it is the maximum distance between the photocell and the object, in the case of reflector or barrier types it is the distance between unit and the reflector or between units. (See drawing)

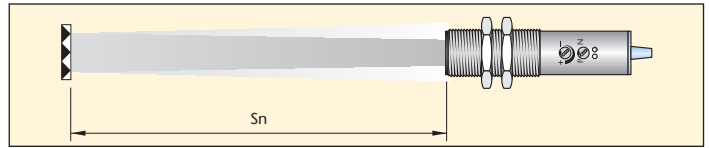

LIGHT ON / DARK ON TYPES OF OUTPUT

For the MEYLE photocell the same terminology as inductive and capacitive sensors is used: N.O. = normally open, N.C. = normally closed. This refers to the state of the unit in the absence of product to be sensed. In the case of photocells light on / dark on is used. In the case of the direct reflection types N.O. is light on and N.C. is dark on. For the other types, N.O. is dark on and N.C. is light on.

TYPE OF LIGHT EMITTED

In photocells the light signal is directed via an optical system to the object to be sensed. All the light emitted by MEYLE photocells is solid state and can be red or infrared. It is easily modulated and has an unlimited life.

POWER ON DELAY

This is the time lapse between providing a power supply and the activation of the output and is to avoid unwanted switching when the unit is powered.

SWITCHING FREQUENCY

The maximum ON /OFF frequency that the photocell can carry out per second. The maximum values of every unit can be found in the technical characteristics.

NOMINAL VOLTAGE (Vn)

Indicates the maximum and minimum voltage values within which the photocell works correctly.

RESIDUAL RIPPLE

This is the relationship as a percentage between the alternating voltage (peak to peak) superimposed on the continuous supply voltage.

MAX OUTPUT CURRENT

This is the max output current of the photoelectric sensor in continuous function.

ABSORPTION

This is the max current consumption of the photocell referred to the maximum limit of the nominal voltage and without load.

VOLTAGE DROP

This is the voltage drop measured with the photocell with output activates.

SHORT CIRCUIT PROTECTION

All direct current photocells have an incorporated protection which protects the internal circuits from damage in the case of a short circuit on the output stage. Once the short circuit is eliminated the photocell resets.

INTERFERENCE FROM EXTERNAL LIGHT

The table shows the maximum limit of an incandescent light or sunlight. Beyond this limit the photocell may not work correctly due to interference on the receiver.

TEMPERATURE LIMITS

Temperature limits between which the correct functioning of the unit is guaranteed.

DEGREE OF PROTECTION

This is expressed in IP followed by two numbers. In the case of photocells the first always 6 (completely protected against dust) and the second can be 5 (protection against water spray) or 7 (protection against full immersion).

CONNECTION IN SERIES AND PARALLEL

CONNECTION OF D.C. TYPES IN SERIES (AND LOGIC)

The photoelectric sensors connected in this way will activate one output when they are excited simultaneously. In this application it is necessary to take into account the following:

- voltage drop
- absorption of each photoelectric sensor
- absorption of the final load.

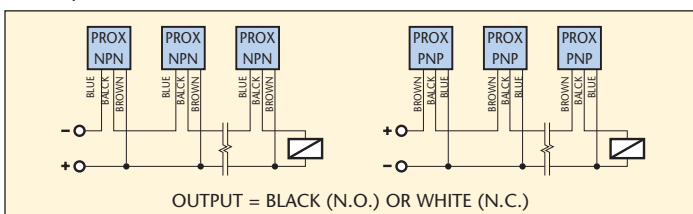

in series or in parallel.

It is important in the case of parallel connection that the connection is made to the same phase. When connected this way it is important to pay attention to the total current loss (each photocell ≤ 2 mA) which can cause problems in a minimum load.

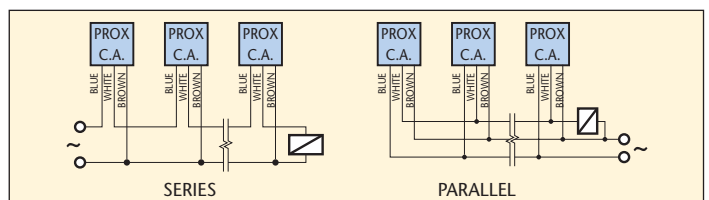

CONNECTION OF D.C. TYPES IN PARALLEL (OR LOGIC)

Connected in this way all photoelectric sensors can activate the common output independently when excited. In D.C. types put a decoupling diode as indicated.

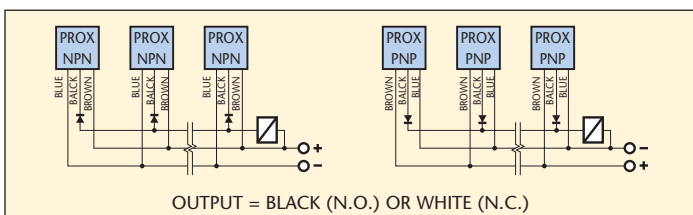

SUGGESTION FOR SUPPLYING VOLTAGE TO PHOTOELECTRIC SENSORS

The supply voltage should be adjusted according to the characteristics of the sensor used. It is recommended to use transformer with secondary voltage Vac lower than the direct voltage Vdc required.

The secondary voltage Vac is found as follows:

$$V_{ac} = (V_{dc} + 1) : 1,41$$

The supply voltage Vdc of the sensor should be filtered with a capacity C at least 470 μ F for each 200 mA used.

If the supply voltage Vdc is high it is recommended to follow the diagram B with a proper voltage stabilizer.

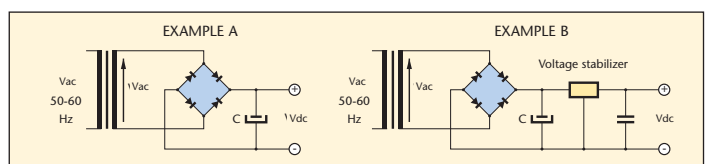

A.C. SUPPLY SERIES OR PARALLEL CONNECTION

In this type a short circuit on the output is not allowed. Incorrect connection can cause irreparable damage to the photocell. Connection can be carried out

PHOTOELECTRIC SENSORS FT18M SERIES 10 ÷ 30 VDC



STAINLESS STEEL CYLINDRICAL HOUSING M18x1
 PROGRAMMABLE OUTPUT NPN/PNP
 FUNCTIONS NO + NC
 SENSITIVITY ADJUSTMENT
 AXIAL BEAM

TECHNICAL CHARACTERISTICS

Dimensions mm

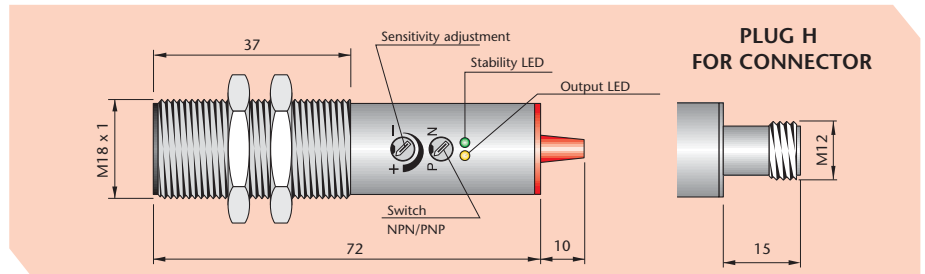

TYPE	DIRECT REFLECTION		REFLECTION WITH REFLECTOR	POLARIZED REFLECTION WITH REFLECTOR	THRU BEAM		
	FT18M-CP2	FT18M-CP4	FT18M-CR	FT18M-CAR	RECEIVER	EMITTER	
MODEL WITH CABLE	FT18M-CP2	FT18M-CP4	FT18M-CR	FT18M-CAR	FT18M-CBR	FT18M-CBE	
MODEL WITH H PLUG	FT18M-CP2-H	FT18M-CP4-H	FT18M-CR-H	FT18M-CAR-H	FT18M-CBR-H	FT18M-CBE-H	
Sensing range (Sn)	cm	20*	40*	250**	100**	1500	
Programmable output	NPN/PNP			NO + NC		-	
Light source	Led	Infrared		Red	Infrared		
Power ON delay	mSec	≤ 75					
Switching frequency	Hz	700			250		
Continuous voltage (Res. ripple ≤10%)	V	10 ÷ 30					
Max output current	mA	200			-		
Max current consumption at 24 Vdc	mA	≤ 50	≤ 20			≤ 35	
Voltage drop (I out = 200 mA)	V	≤ 3			-		
Short circuit protection		Incorporated			-		
Light immunity		> 10.000 Lux			-		
LED	Yellow	Operation indicator				Power supply (Red led)	
	Green	Stability					
Temperature limit	°C	Storage -20 ÷ +90°C • Working -20 ÷ +50°C					
Protection degree	IP	67					
Housing		Stainless steel AISI 303					
Cable	2m	4 x 0.25 mm ²			4 x 0,25 mm ²	2 x 0,50 mm ²	
Connector plug		H					

WIRING DIAGRAMS

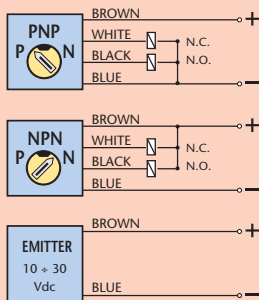

N.B.: On request is available cable for sensors with different length 3.5 - 5 - 7.5 - 10 m.

CONNECTION WHIT H PLUG FOR CONNECTORS SEE PAGE 85

VIEW OF MALE CONNECTOR H

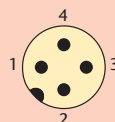

2 WIRINGS (EMITTER) 4 WIRINGS
 1 = Brown / + 1 = Brown / +
 3 = Blue / - 3 = Blue / -
 4 = Black / output NO 4 = Black / output NO
 2 = White / output NC 2 = White / output NC

TYPES

Direct reflection (P type)

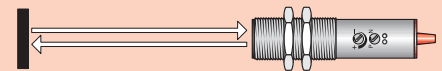

Reflection with reflector (R type)

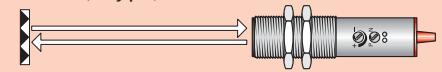

Polarized reflection (AR type)



Thru beam emitter + receiver (B type)

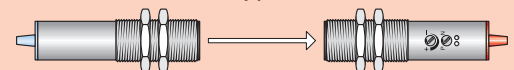

*The sensing distance is related to matt white paper dim. 10 x 10 cm. **The sensing distance is related to CT80 reflector.

Meyer Industrie-Electronic GmbH - MEYLE

Carl-Bosch-Straße 8
 49525 Lengerich/Germany
 Internet: www.meyle.de

Tel.: (+49) 05481/9385-0
 Fax: (+49) 05481/9385-12
 E-Mail: sales@meyle.de

PHOTOELECTRIC SENSORS FT18M SERIES 90° BEAM 10 ÷ 30 VDC



STAINLESS STEEL CYLINDRICAL HOUSING M18x1
 PROGRAMMABLE OUTPUT NPN/PNP
 FUNCTIONS NO + NC
 SENSITIVITY ADJUSTMENT
 90° BEAM

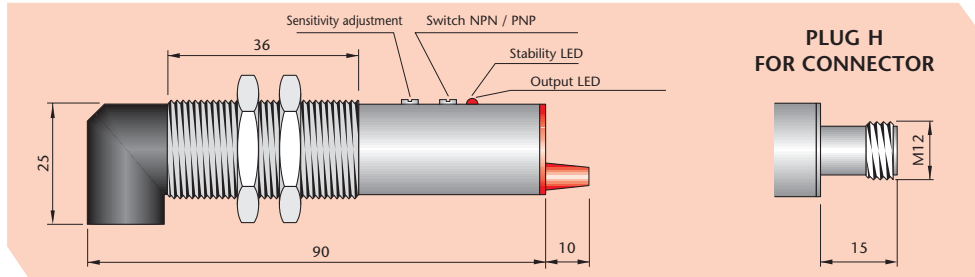

DIRECT REFLECTION		REFLECTION WITH REFLECTOR	POLARIZED REFLECTION WITH REFLECTOR	RECEIVER THRU BEAM	EMITTER
FT18M-CP2-90	FT18M-CP4-90	FT18M-CR-90	FT18M-CAR-90	FT18M-CBR-90	FT18M-CBE-90
FT18M-CP2-90-H	FT18M-CP4-90-H	FT18M-CR-90-H	FT18M-CAR-90-H	FT18M-CBR-90-H	FT18M-CBE-90-H
20*	40*	250**	100**	1500	
NPN/PNP			NO + NC	-	
Infrared			Red	Infrared	
≤ 75					
700				250	
10 ÷ 30					
200			-		
≤ 50	≤ 20			≤ 35	
≤ 3			-		
Incorporated			-		
> 10.000 Lux			-		
Operation indicator			Power supply (Red led)		
Stability					
Storage -20 ÷ +90°C • Working -20 ÷ +50°					
67					
Stainless steel AISI 303					
4 x 0,25 mm ²			4 x 0,25 mm ²		2 x 0,50 mm ²
H					

INSTRUCTIONS FOR THE PROGRAMMING AND ADJUSTMENT

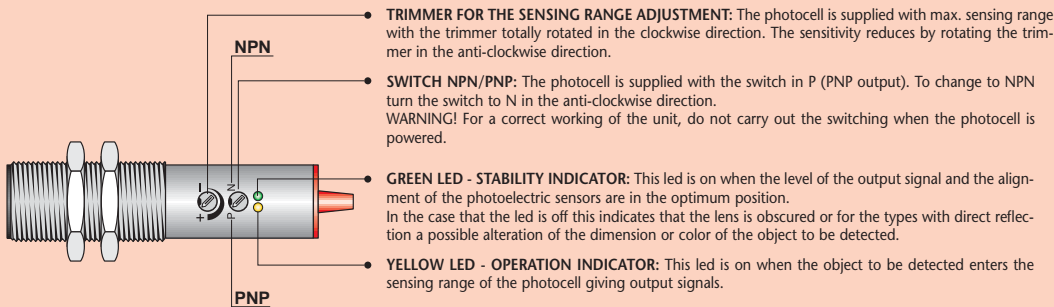

NOTE! Before giving a power supply to the photocell it is recommended that the same unit be programmed by using the switch in the required function NPN or PNP.

NOTE! It is recommended that the trimmer and the switch be rotated very carefully by using a proper tool otherwise these can be seriously damaged.

EMITTER FT18M-CBE

POWER SUPPLY LED POSITION

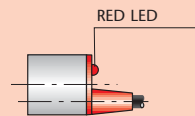

TYPES WITH CABLE

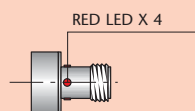

TYPES WITH CONNECTOR

Meyer Industrie-Electronic GmbH - MEYLE

Carl-Bosch-Straße 8
 49525 Lengerich/Germany
 Internet: www.meyle.de

Tel.: (+49) 05481/9385-0
 Fax: (+49) 05481/9385-12
 E-Mail: sales@meyle.de

PHOTOELECTRIC

PHOTOELECTRIC SENSORS FT18 SERIES 20 ÷ 250 VAC



CYLINDRICAL HOUSING M18x1
 3 WIRES A.C.
 PROGRAMMABLE OUTPUT NO/NC
 SENSITIVITY ADJUSTMENT
 AXIAL BEAM

TECHNICAL CHARACTERISTICS

Dimensions mm

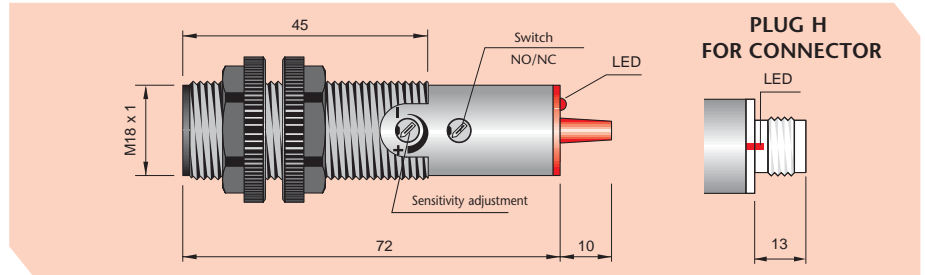

TYPE	DIRECT REFLECTION		REFLECTION WITH REFLECTOR	POLARIZED REFLECTION WITH REFLECTOR	THRU BEAM		
	FT18-AP2	FT18-AP4	FT18-AR	FT18-AAR	RECEIVER FT18-ABR	EMITTER FT18-ABE	
MODEL WITH CABLE	FT18-AP2	FT18-AP4	FT18-AR	FT18-AAR	FT18-ABR	FT18-ABE	
MODEL WITH H PLUG	FT18-AP2-H	FT18-AP4-H	FT18-AR-H	FT18-AAR-H	FT18-ABR-H	FT18-ABE-H	
Sensing range (Sn)	cm	20*	40*	250**	100**	1500	
Programmable output	NO or NC					-	
Light source	Led	Infrared		Red	Infrared		
Power ON delay	mSec	≤ 75					
Switching frequency	Hz	15					
Alternating voltage 50 ÷ 60 Hz	V	20 ÷ 250					
Max output current	mA	300					
Max peak current for 20 ms	A	3					
Max current consumption	mA	≤10					
Voltage drop (Sensor ON) (Max)	V	1.5					
Short circuit protection		Incorporated					
Light immunity		> 10.000 Lux					
Led		Operation indicator					Power supply
Temperature limit	°C	Storage -20 ÷ +90°C • Working -20 ÷ +50°C					
Protection degree	IP	67					
Plastic housing		Gray makrolon (On request stainless steel AISI 303)					
Cable	2m	3 x 0.35 mm ²					2 x 0,50 mm ²
Connector plug		H					

WIRING DIAGRAMS

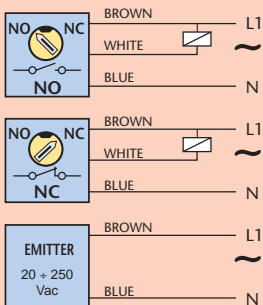

N.B.: On request is available cable for sensors with different length 3.5 - 5 - 7.5 - 10 m.

CONNECTIONS WITH H PLUG

FOR CONNECTORS SEE PAGE 85

VIEW OF MALE CONNECTOR H

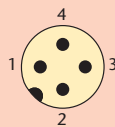

2 WIRINGS (EMITTER) 4 WIRINGS
 1 = L1 1 = Brown / L1
 3 = N 3 = Blue / N
 4 = White / NO - NC Programmable

N.B.: Use female connector without led.

TYPES

Direct reflection (P type)

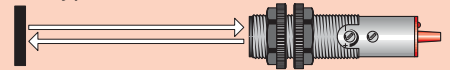

Reflection with reflector (R type)

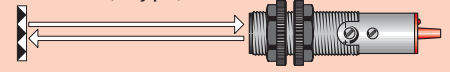

Polarized reflection with reflector (AR type)

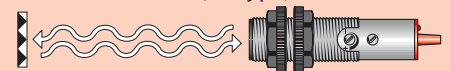

Thru beam emitter + receiver (B type)

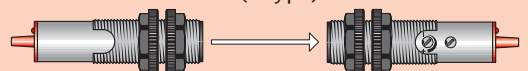

*The sensing distance is related to matt white paper dim. 10 x 10 cm. **The sensing distance is related to CT80 reflector.

Meyer Industrie-Electronic GmbH - MEYLE

Carl-Bosch-Straße 8
 49525 Lengerich/Germany
 Internet: www.meyle.de

Tel.: (+49) 05481/9385-0
 Fax: (+49) 05481/9385-12
 E-Mail: sales@meyle.de

PHOTOELECTRIC SENSORS FT18 SERIES 90° BEAM 20 ÷ 250 VAC



CYLINDRICAL HOUSING M18x1
 3 WIRES A.C.
 PROGRAMMABLE OUTPUT NO/NC
 SENSITIVITY ADJUSTMENT
 90° BEAM

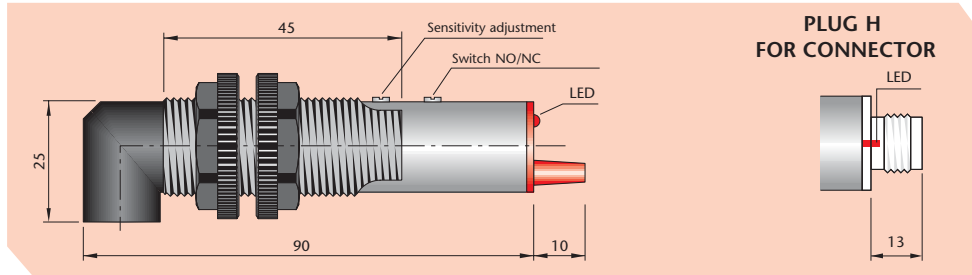

DIRECT REFLECTION		REFLECTION WITH REFLECTOR	POLARIZED REFLECTION WITH REFLECTOR	RECEIVER THRU BEAM	EMITTER
FT18-AP2-90	FT18-AP4-90	FT18-AR-90	FT18-AAR-90	FT18-ABR-90	FT18-ABE-90
FT18-AP2-90-H	FT18-AP4-90-H	FT18-AR-90-H	FT18-AAR-90-H	FT18-ABR-90-H	FT18-ABE-90-H
20*	40*	250**	100**	1500	
NO or NC					-
Infrared			Red	Infrared	
≤ 75					
15					-
20 ÷ 250					
300					-
3					-
≤ 10					
1.5					-
Incorporated					-
> 10.000 Lux					-
Operation indicator					Power supply
Storage -20 ÷ +90°C • Working -20 ÷ +50°C					
67					
Gray makrolon (On request stainless steel AISI 303)					
3 x 0.35 mm ²					2 x 0,50 mm ²
H					

INSTRUCTIONS FOR THE PROGRAMMING AND ADJUSTMENT

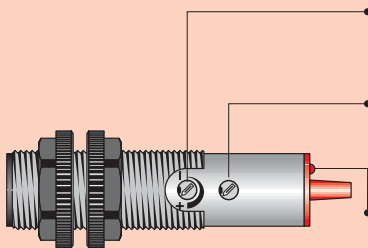

- TRIMMER FOR THE SENSING RANGE ADJUSTMENT:** The photocell is supplied with max. sensing range with the trimmer totally rotated in the clockwise direction. The sensitivity reduces by rotating the trimmer in the anti-clockwise direction.
- SWITCH NO/NC:** The photocell is supplied with switch in NO position (in absence of the object to be detected the output is deactivated). To change to N.C. (in absence of the object to be sensed the output is activated) turn the switch to N.C. in the anti-clockwise direction.
- LED FOR INDICATION OF OPERATION:** This indicates the output of the photocell, in the absence of the object to be sensed it is off with output N.O. and is on with output N.C. this changes state when the object to be sensed enters into the sensing area of the photocell.

NOTE! Before giving a power supply to the photocell it is recommended that the same unit be programmed by using the switch in the required function NO or NC.

NOTE! It is recommended that the trimmer and the switch be rotated very carefully by using a proper tool otherwise these can be seriously damaged.

EMITTER FT18-ABE

POSITION OF POWER SUPPLY LED

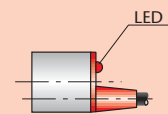

TYPES WITH CABLE

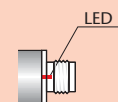

TYPES WITH CONNECTOR

Meyer Industrie-Electronic GmbH - MEYLE

Carl-Bosch-Straße 8
 49525 Lengerich/Germany
 Internet: www.meyle.de

Tel.: (+49) 0 54 81/93 85-0
 Fax: (+49) 0 54 81/93 85-12
 E-Mail: sales@meyle.de

PHOTOELECTRIC SENSORS FTQ SERIES NPN/PNP 10 ÷ 30 VDC



COMPACT SIZE 50 x 50 x 18 mm
 PROGRAMMABLE OUTPUT NPN/PNP
 OUTPUT FUNCTION NO + NC
 SENSITIVITY ADJUSTMENT

TECHNICAL CHARACTERISTICS

Dimensions mm

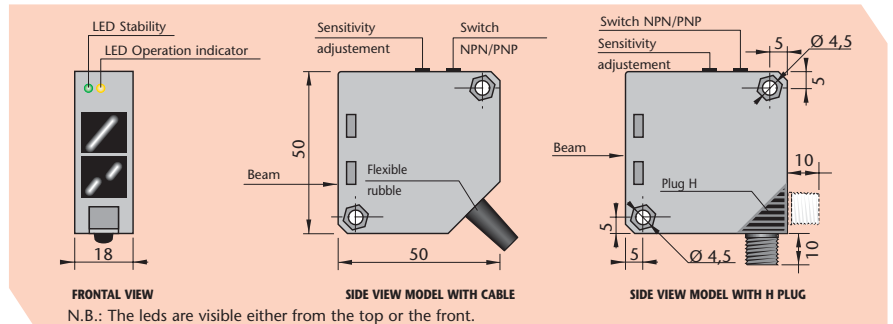

TYPE	DIRECT REFLECTION		REFLECTION WITH REFLECTOR	POLARIZED REFLECTION WITH REFLECTOR	RECEIVER	THRU BEAM	EMITTER
	FTQ-CP	FTQ-CR	FTQ-CR	FTQ-CAR	FTQ-CBR	FTQ-CBE	FTQ-CBE
MODEL WITH CABLE	FTQ-CP	FTQ-CR	FTQ-CR	FTQ-CAR	FTQ-CBR	FTQ-CBE	FTQ-CBE
MODEL WITH H PLUG	FTQ-CP-H	FTQ-CR-H	FTQ-CR-H	FTQ-CAR-H	FTQ-CBR-H	FTQ-CBE-H	FTQ-CBE-H
Sensing range (Sn)	cm	80*	500**	300**	2000		
Programmable output	NPN/PNP		NO + NC				
Light source	Led	Infrared		Red	Infrared		
Power on delay	mSec			≤ 80			
Switching frequency	Hz	700			250		
Continuous voltage (Res. ripple ≤10%)	V			10 ÷ 30			
Multivoltage AC/DC	V						
Max output current	mA			200			
Max current consumption at 24 Vdc	mA	≤ 50			≤ 20	≤ 50	
Voltage drop (I out = 200 mA)	V			≤ 3			
Short circuit protection				Incorporated			
Light immunity				>10.000 Lux			
Led	Yellow			Operation indicator	Power supply		
	Green			Stability control	(Red Led)		
Temperature limits	°C			Working temperature: -20 ÷ +50 / Storage temperature: -20 ÷ +65			
Protection degree	IP			65			
Plastic housing				Gray ABS			
Cable	2m			4 x 0.25 mm ²	2 x 0.50 mm ²		
Connector plug				H			

WIRING DIAGRAMS

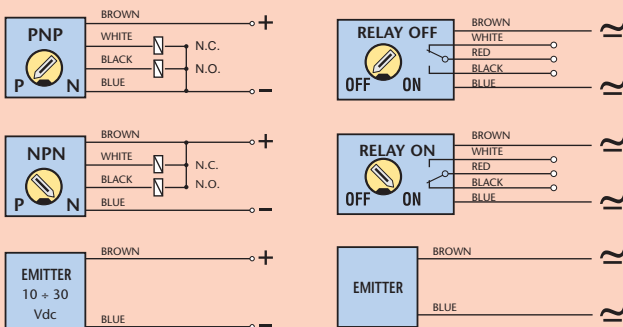

N.B.: On request is available cable for sensors with different length 3.5 - 5 - 7.5 - 10 m.

CONNECTION WHIT H PLUG

FOR THE CONNECTORS SEE PAGE 85

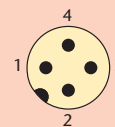

VIEW OF MALE CONNECTOR PLUG H

MODELS NPN/PNP

2 WIRES (EMITTER)

- 1 = Brown / +
- 3 = Blue / -

4 WIRES (OTHER MODELS)

- 1 = Brown / +
- 3 = Blue / -
- 4 = Black / output NPN-PNP/N.O.
- 2 = White / output NPN-PNP/N.C.

MODELS RELAY

2 WIRES (EMITTER)

- 1 = Brown / ~
- 3 = Blue / ~
- 2-4 = Relay contact

N.B. With relay in OFF position the contact 2-4 is open. With connectors with cable the contact 2-4 corresponds to the Black-White wiring.

*The sensing distance is related to matt white paper dim. 20 x 20 cm. **The sensing distance is related to CT80 reflector.

Meyer Industrie-Electronic GmbH - MEYLE

Carl-Bosch-Straße 8
 49525 Lengerich/Germany
 Internet: www.meyle.de

Tel.: (+49) 054 81/9385-0
 Fax: (+49) 054 81/9385-12
 E-Mail: sales@meyle.de

PHOTOELECTRIC SENSORS FTQ SERIES - RELAY

12 ÷ 240 VAC/DC



COMPACT SIZE 50 x 50 x 18 mm
RELAY OUTPUT
PROGRAMMABLE RELAY ON/OFF
SENSITIVITY ADJUSTMENT

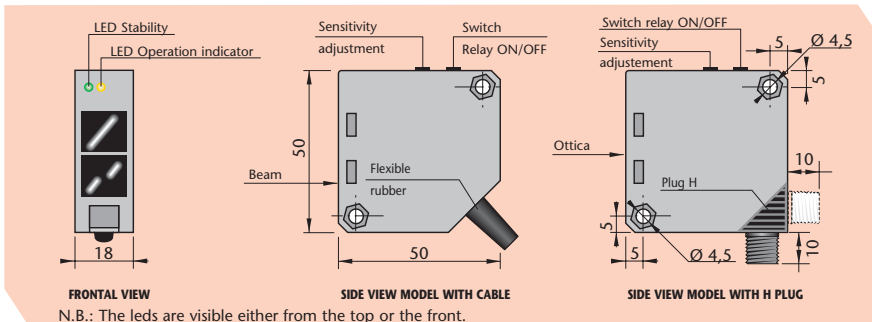

FRONTAL VIEW SIDE VIEW MODEL WITH CABLE SIDE VIEW MODEL WITH H PLUG

N.B.: The leds are visible either from the top or the front.

H PLUG - M12 CONNECTOR

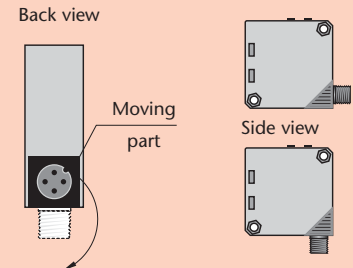

Turn in the clockwise to choose the direction of the connector exit.

TYPES

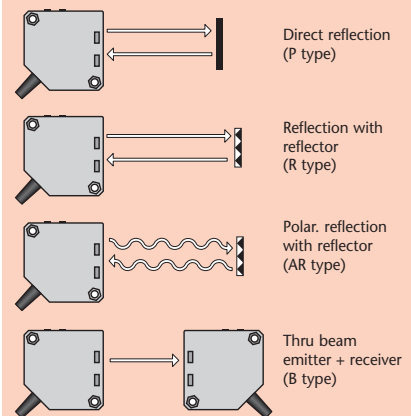

DIRECT REFLECTION	REFLECTION WITH REFLECTOR	POLARIZED REFLECTION WITH REFLECTOR	RECEIVER	THRU BEAM	EMITTER
FTQ-P-R	FTQ-R-R	FTQ-AR-R	FTQ-BR-R		FTQ-BE-R
FTQ-P-R-H	FTQ-R-R-H	FTQ-AR-R-H	FTQ-BR-R-H		FTQ-BE-R-H
80*	500**	300**		2000	
RELAY ON/OFF (Programmable)					
Infrared		Red	Infrared		
≤ 100					
10					
12 ÷ 240					
12 ÷ 240					
Contact relay 1A 220Vac				-	
1.8 VA				1 VA	
>10.000 Lux					
Operation indicator				Power supply	
Stability control				(Red Led)	
Working temperature: -20 ÷ +50 / Storage temperature: -20 ÷ +65					
65					
Gray ABS					
5 x 0.35 mm ²			2 x 0.50 mm ²		
H					

MOUNTING BRACKET ST2

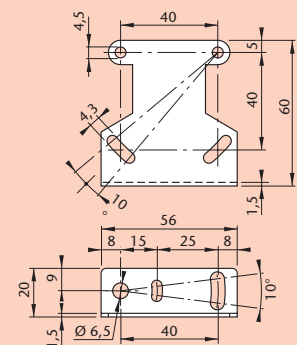

EMITTER FTQ - CBE/FTQ - BE - R

POSITION OF POWER SUPPLY LED

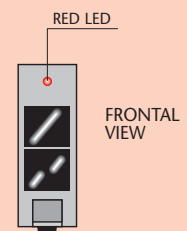

INSTRUCTIONS FOR THE PROGRAMMING AND ADJUSTMENT

FTQ MODELS (NPN/PNP)

- GREEN LED - STABILITY INDICATOR:** This led is on when the level of the output signal and the alignment of the photoelectric sensors are in the optimum position. In the case that the led is off this indicates that the lens is obscured or for the types with direct reflection a possible alteration of the dimension or color of the object to be detected.
- YELLOW LED - OPERATION INDICATOR:** This led is on when the object to be detected enters the sensing range of the photocell giving output signals.
- TRIMMER FOR THE SENSING RANGE ADJUSTMENT:** The photocell is supplied with max. sensing range with the trimmer totally rotated in the clockwise direction. The sensitivity reduces by rotating the trimmer in the anti-clockwise direction.
- SWITCH NPN/PNP:** The photocell is supplied with the switch in P (PNP output). To change to NPN turn the switch to N in the clockwise direction.

FTQ MODELS (RELAY)

- SWITCH RELAY ON/OFF:** The photocell is supplied with the switch in OFF (relay de-energized without object). To change to ON (relay energized without object) turn the switch to ON in the clockwise direction.

NOTE! Before giving a power supply to the photocell it is recommended that the same unit be programmed by using the switch in the required function NPN or PNP and NO or NC.

Meyer Industrie-Electronic GmbH - MEYLE

Carl-Bosch-Straße 8
49525 Lengerich/Germany
Internet: www.meyle.de

Tel.: (+49) 05481/9385-0
Fax: (+49) 05481/9385-12
E-Mail: sales@meyle.de

PHOTOELECTRIC SENSORS FT18 SERIES 10 ÷ 30 VDC



PLASTIC CYLINDRICAL HOUSING M18x1
 PROGRAMMABLE OUTPUT NPN/PNP
 FUNCTIONS NO+NC
 AXIAL BEAM
 90° BEAM

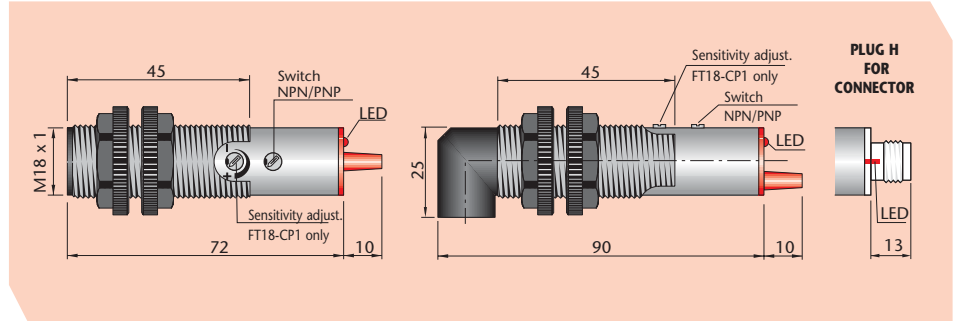

TECHNICAL CHARACTERISTICS

Dimensions mm

TYPE	DIRECT REFLECTION		REFLECTION WITH REFLECTOR	POLARIZED REFLECTION WITH REFLECTOR	THRU BEAM		
	RECEIVER	EMITTER	RECEIVER	EMITTER	RECEIVER	EMITTER	
MODEL WITH CABLE	FT18-CP	FT18-CP1	FT18-CR	FT18-CAR	FT18-CBR	FT18-CBE	
MODEL WITH H PLUG	FT18-CP-H	FT18-CP1-H	FT18-CR-H	FT18-CAR-H	FT18-CBR-H	FT18-CBE-H	
MODEL WITH CABLE	FT18-CP-90	FT18-CP1-90	FT18-CR-90	FT18-CAR-90	FT18-CBR-90	FT18-CBE-90	
MODEL WITH H PLUG	FT18-CP-90-H	FT18-CP1-90-H	FT18-CR-90-H	FT18-CAR-90-H	FT18-CBR-90-H	FT18-CBE-90-H	
Sensing range (Sn)	cm	10*	0 ÷ 10*	250**	100**	1500	
Programmable output	NPN/PNP			NO + NC		-	
Light source	Led	Infrared		Red	Infrared		
Power on delay	mSec	≤ 75					
Switching frequency	Hz	700					
Continuous voltage (Res. ripple ≤ 10%)	V	10 ÷ 30					
Max output current	mA	200				-	
Max current consumption at 24 Vdc	mA	≤ 50	≤ 20			≤ 35	
Voltage drop (I out = 200mA)	V	≤ 3					
Short circuit protection		Incorporated					
Light immunity		> 10.000 Lux					
Led		Operation indicator					Power supply
Temperature limits	°C	Storage -20 ÷ +90°C • Working -20 ÷ +50°C					
Protection degree	IP	67					
Plastic housing		Gray makrolon					
Cable	2m	4 x 0.25 mm ²				2 x 0,50 mm ²	
Connector plug		H					

NOTE! Before giving a power supply to the photocell it is recommended that the same unit be programmed by using the switch in the required function NPN or PNP.

WIRING DIAGRAMS

N.B.: On request is available cable for sensors with different length 3.5 - 5 - 7.5 - 10 m.

CONNECTIONS WITH H PLUG

FOR CONNECTORS SEE PAGE 85

VIEW OF MALE CONNECTOR H

2 WIRINGS (EMITTER) 4 WIRINGS
 1 = Brown / + 1 = Brown / +
 3 = Blue / - 3 = Blue / -
 2 = White / output NC 4 = Black / output NO

TYPES

Direct reflection (P type)

Reflection with reflector (R type)

Polarized reflection with reflector (AR type)

Thru beam emitter + receiver (B type)

*The sensing distance is related to matt white paper dim. 10 x 10 cm. **The sensing distance is related to CT80 reflector.

Meyer Industrie-Electronic GmbH - MEYLE

Carl-Bosch-Straße 8
 49525 Lengerich/Germany
 Internet: www.meyle.de

Tel.: (+49) 05481/9385-0
 Fax: (+49) 05481/9385-12
 E-Mail: sales@meyle.de

PHOTOELECTRIC SENSORS FT13-CF SERIES FORK SHAPE



DETECTING NON TRANSPARENT AND TRANSLUCENT MATERIALS
 METALLIC HOUSING WITH 13 mm FORK SHAPE
 SENSITIVITY ADJUSTMENT
 OUTPUT NPN - PNP
 FUNCTIONS NO - NC

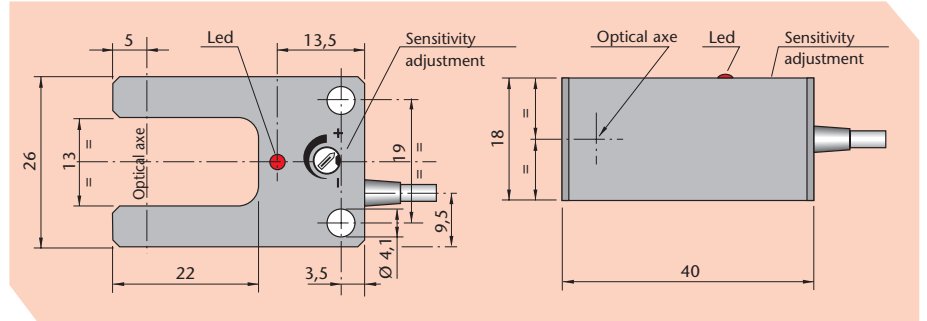

TECHNICAL CHARACTERISTICS

Dimensions mm

AMPLIFIED MODELS 3 WIRES D.C.	NPN	NO	FT13-CF NPN NO
		NC	FT13-CF NPN NC
	PNP	NO	FT13-CF PNP NO
		NC	FT13-CF PNP NC
Fork shape dimension	mm	13	
Light source	Led	Infrared	
Power on delay	mSec	≤ 75	
Switching frequency	Hz	500	
Continuous voltage (Res. ripple ≤ 10%)	V	10 ÷ 30	
Max output current	mA	200	
Max current consumption at 24 Vdc	mA	≤ 15	
Voltage drop (I out = 200mA)	V	≤ 1,5	
Short circuit protection		Incorporated	
Light immunity	Lux	Sun light >10.000 Lux – Incandescent lamp >3.000 Lux	
Led		Operation indicator	
Temperature limits	°C	Storage -40 ÷ +85°C • Working -25 ÷ +50°C	
Protection degree	IP	67	
Plastic housing		Nickelled brass	
Cable	2m	3 x 0.25 mm ²	

WIRING DIAGRAMS

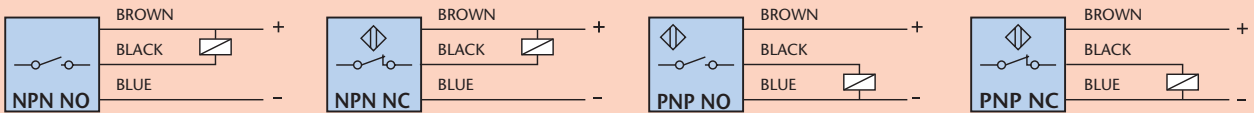

N.B.: On request is available cable for sensors with different length 3.5 - 5 - 7.5 - 10 m.

SHUTTERS OT SERIES FOR FT18 THRU BEAM

These are accessories for M18 emitter and receiver barrier systems, they reduce the light beam allowing the units to sense small objects (up to 1 mm) in precision applications. The kit is made up of a threaded metal locknut, a protection glass, a sealing gasket and a perforated disc which is available with different diameters of hole; this should be assembled, as shown, both on the emitter and receiver.

The obtainable distances referred to the minimum dimensions of the object that can be sensed are indicated in the table.

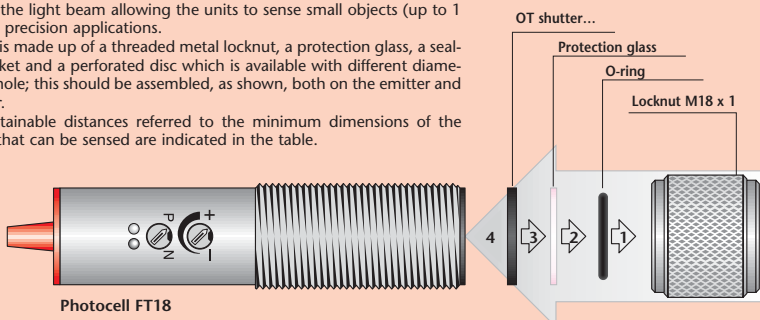

MODEL		OT1	OT2	OT3	OT4	OT6	OT8
FT18	DISTANCE (cm)	10	50	70	90	130	200
	OBJECT (mm)	1	1	1	1	1,5	2,5

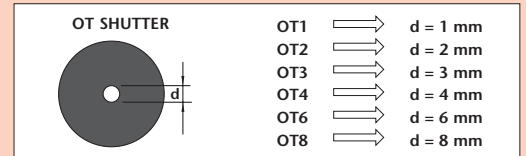

Meyer Industrie-Electronic GmbH - MEYLE

Carl-Bosch-Straße 8
 49525 Lengerich/Germany
 Internet: www.meyle.de

Tel.: (+49) 05481/9385-0
 Fax: (+49) 05481/9385-12
 E-Mail: sales@meyle.de

PHOTOELECTRIC

CHARACTERISTIC CURVES OF FT18 - FTQ TYPES

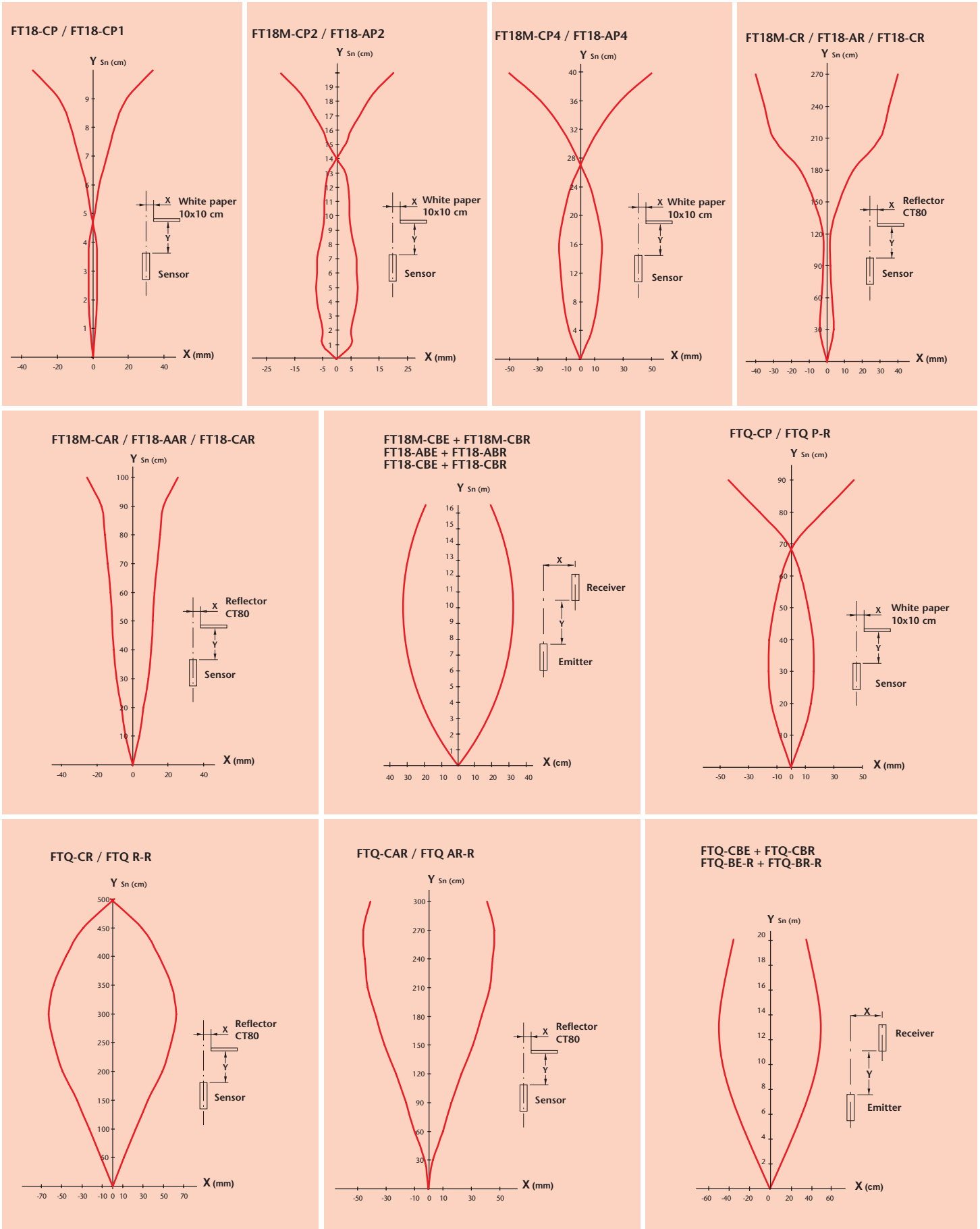

Meyer Industrie-Electronic GmbH - MEYLE

Carl-Bosch-Straße 8
49525 Lengerich/Germany
Internet: www.meyle.de

Tel.: (+49) 05481/9385-0
Fax: (+49) 05481/9385-12
E-Mail: sales@meyle.de

REFLECTORS TYPE CT

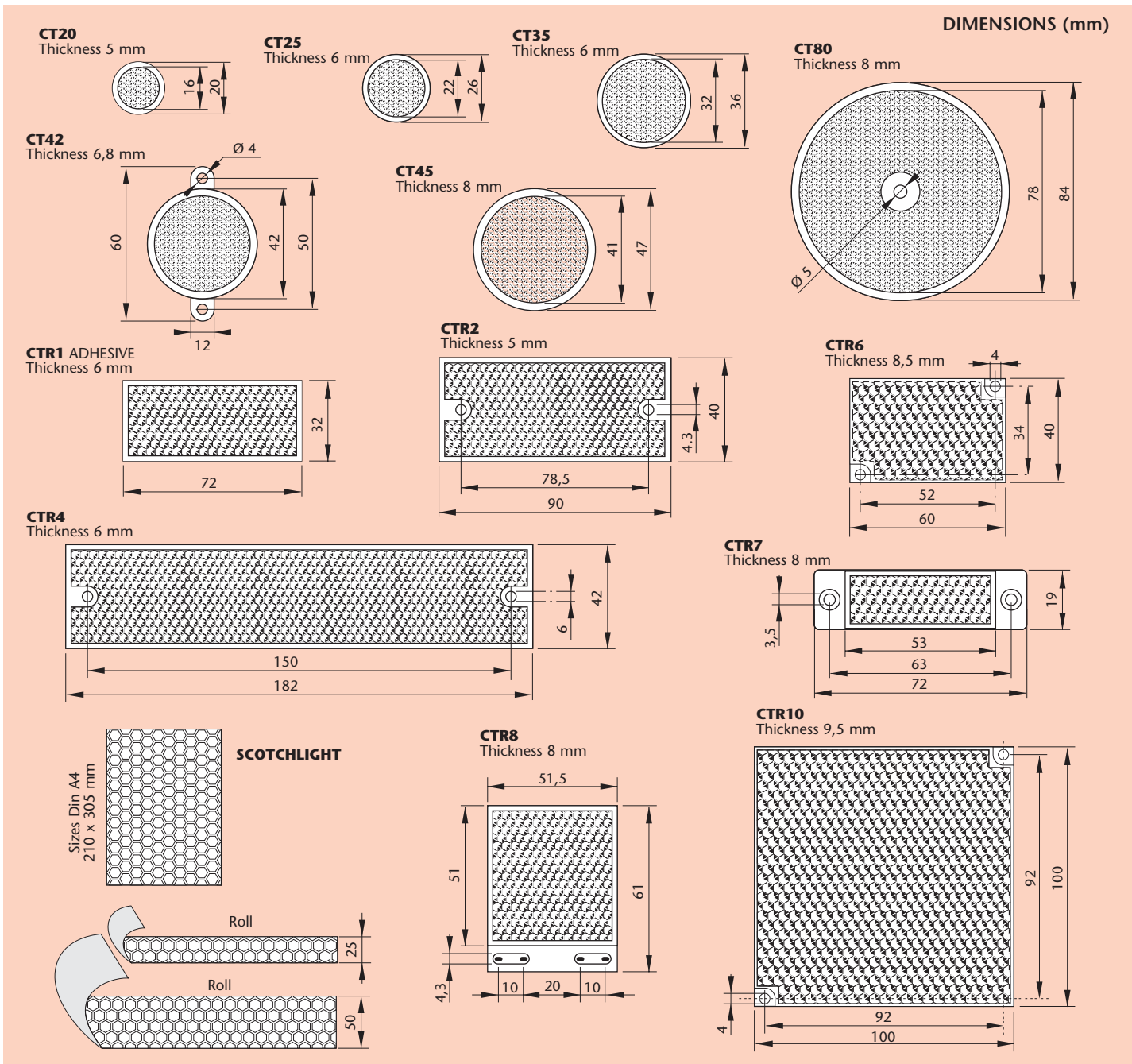
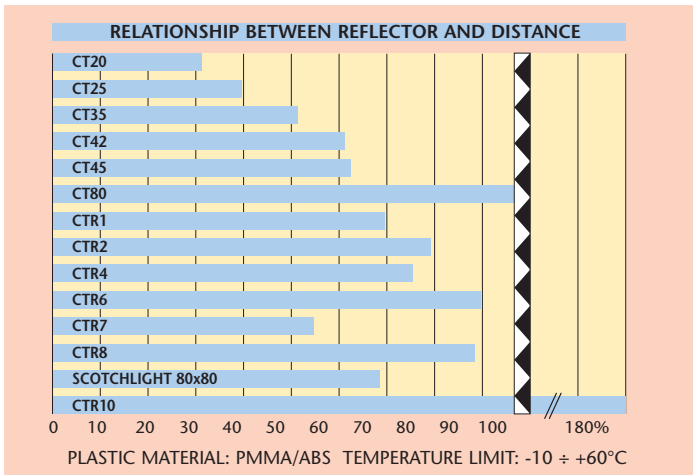

PHOTOELECTRIC

Meyer Industrie-Electronic GmbH - MEYLE

Carl-Bosch-Straße 8
 49525 Lengerich/Germany
 Internet: www.meyle.de

Tel.: (+49) 05481/9385-0
 Fax: (+49) 05481/9385-12
 E-Mail: sales@meyle.de

FIBER OPTIC SENSORS - GENERAL DESCRIPTION



Fiber optic sensors function electronically like any other photoelectric sensor with the difference that the light emitted and received is transported by an optical fiber the end of which is very small and in different forms and it can be installed some distance from the electronic circuit.

The reduced dimension of the fiber allows the sensing of very small objects and their installation in areas where other sensors would not fit.

Furthermore they can be used in explosion risk areas as well as in liquids and have a very high resistance to mechanical damage and to vibrations which makes them suitable for installation on machinery where movement is involved.

They are available in the reflection and barrier emitter/receiver.

The light source is red and the length of the standard fibers is 2 metres.

TYPES

FT18M-CFR WITH FIBERS FOR DIRECT REFLECTION

In this type of function the red light emitter and receiver are contained in one fiber (MULTI CORED) or side by side (DOUBLE CORED).

The sensing is obtained by the reflection of the rays of the object to be detected. The parameters that influence the sensing distance are mainly the colour, the reflective or the roughness of the surface to be sensed.

The maximum sensing distances mentioned in the technical characteristics refer to results obtained with a piece of matt white paper dimension 10 x 10 cm.

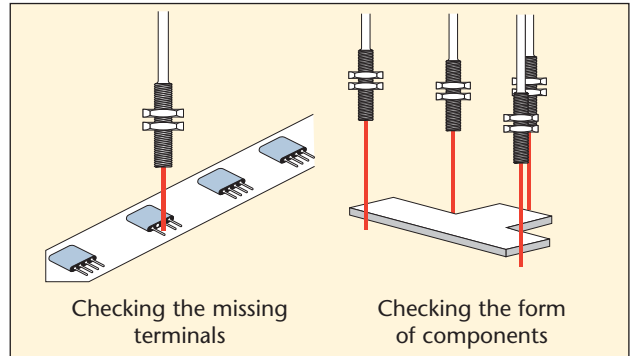
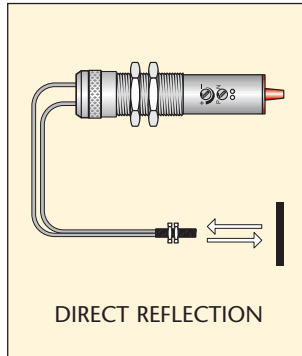

FT18M-CFR WITH BARRIER FIBERS EMITTER/RECEIVER

In this type of function the red light emitter and receiver are facing each other and are made up of a single fiber (SINGLE CORED).

Detection occurs when the rays emitted are interrupted furthermore these fibers can reach at their maximum sensitivity regulation, long distances as there is no dispersion between emitter and receiver. Their power can be increased by using the AT-4101 lenses.

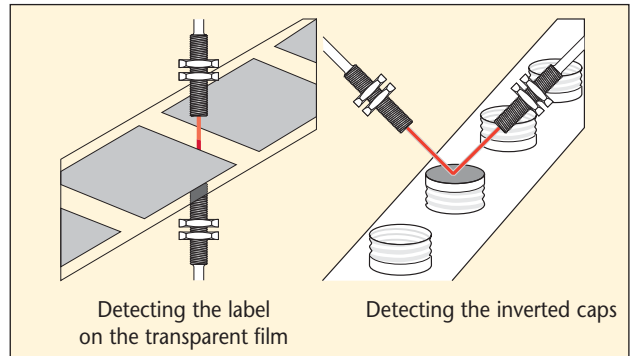
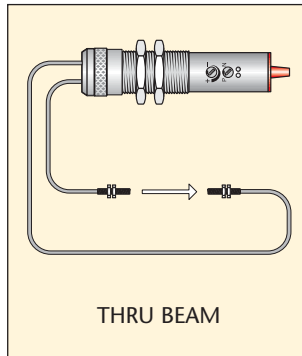

TECHNICAL CHARACTERISTICS

FT18M-CFR AMPLIFIER

- Easy to install by using the available accessories.
- Mechanically robust amplifier in AISI 303 stainless steel.
- Single amplifier for all detection systems.
- Single amplifier for NPN and PNP versions (selection by switch).
- Switch from NPN to PNP without variation in electrical connection.
- Antiphase NO+NC static output.
- Available with 2m cable or M12 H plug connector.

FIBER OPTICS

- Covered in plastic polythene.
- Temperature limits: $-40 \div +70^{\circ}\text{C}$.
- Different types of fiber available.
- In various types it is possible to cut the fiber at the required length.
- Increased detection distance by using the AT-4101 lenses.
- Possibility of being able to divert the rays by 90° in the barrier types by using accessory AT-4102.
- Access in limited spaces with the types that have a sleeve.

FIBER OPTIC SENSORS - FT18M - CFR TYPES



STAINLESS STEEL CYLINDRICAL HOUSING M18 x 1
 PROGRAMMABLE OUTPUT NPN / PNP
 SENSITIVITY ADJUSTMENT
 FUNCTIONS NO + NC

TECHNICAL CHARACTERISTICS

Dimensions mm

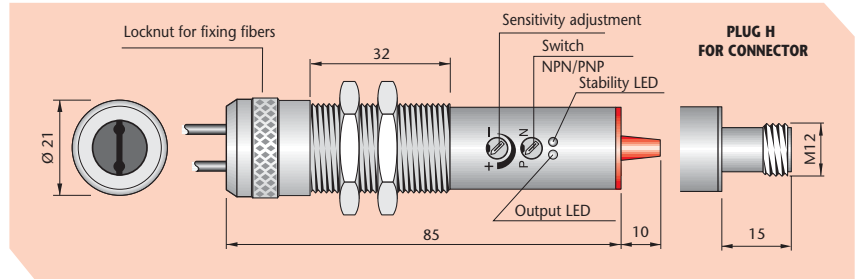

TYPE	ONE TYPE FOR DIRECT REFLECTION OR THRU-BEAM	
MODEL WITH CABLE	FT18M-CFR	
MODEL WITH H PLUG	FT18M-CFR-H	
Programmable output	NPN/PNP	NO + NC
Light source	Led	Red
Power on delay	mSec	≤ 75
Switching frequency	Hz	700
Continuous voltage (Res. ripple ≤10%)	V	10 ÷ 30
Max output current	mA	200
Max current consumption at 24 Vdc	mA	≤ 50
Voltage drop (I out = 200 mA)	V	≤ 3
Short circuit protection	Incorporated	
Light immunity	> 10.000 Lux	
Led	Yellow	Operation indicator
	Green	Stability
Temperature limits	°C	Storage -20 ÷ +90°C • Working -20 ÷ +50°C
Protection degree	IP	65
Housing	Stainless steel AISI 303	
Cable	2m	4 x 0.25 mm ²
Connector plug	H	
Possible wiring connection	See page 69	

WIRING DIAGRAMS

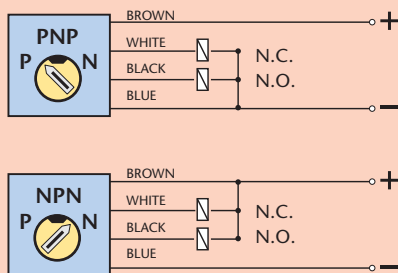

FT18M-CFR with direct reflection fiber
 BLACK WIRE = N.O. WHITE WIRE = N.C.

FT18M-CFR with thru-beam fiber
 BLACK WIRE = N.C. WHITE WIRE = N.O.

CONNECTION WHIT H PLUG FOR CONNECTORS SEE PAGE 85

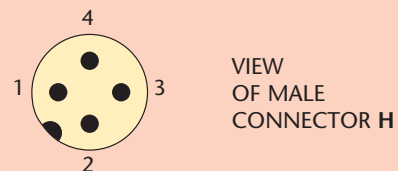

FT18M-CFR-H power supply
 1 = Positive 3 = Negative

FT18M-CFR-H with direct reflection fiber
 4 = NO 2 = NC

FT18M-CFR-H with thru-beam fiber
 4 = NC 2 = NO

FIBER PROBES FTL - FDL



	TYPE	DIMENSIONS mm	SENSING DISTANCE mm	APPLICATION	CUTTING	FIBER TYPE
THRU BEAM TYPES	FTL000*		150	STANDARD	POSSIBLE	SINGLE CORED
	FTL100*		150	STANDARD	POSSIBLE	SINGLE CORED
	FTL300*		150	STANDARD	POSSIBLE	SINGLE CORED
DIRECT REFLECTION TYPES	FDL010		60	STANDARD	POSSIBLE	DOUBLE CORED
	FDL020		60	POSITIONINGS	POSSIBLE	MULTI CORED
	FDL310		60	STANDARD	POSSIBLE	DOUBLE CORED
	FDL120		60	POSITIONINGS	NOT POSSIBLE	MULTI CORED
	FDL210		70	STANDARD	NOT POSSIBLE	DOUBLE CORED
	FDL311		10	DETECTING SMALL OBJECTS	NOT POSSIBLE	DOUBLE CORED

ACCESSORIES

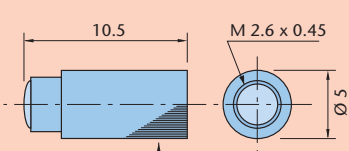

LENS VIEWER AT-4101

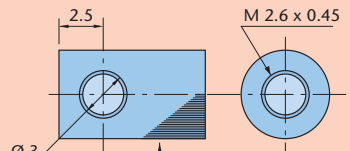

SIDE VIEWER 90° AT-4102

NOTE:

The two accessories can be used only with the following fiber: FTL100. The AT-4101 lens increases the standard distance by approximately 8 times if mounted on the emitter and receiver.

*Thru beam types are supplied emitter + receiver together.

Meyer Industrie-Electronic GmbH - MEYLE

Carl-Bosch-Straße 8
49525 Lengerich/Germany
Internet: www.meyle.de

Tel.: (+49) 05481/9385-0
Fax: (+49) 05481/9385-12
E-Mail: sales@meyle.de

FIBER OPTIC SENSORS - OPERATING PROCEDURES



INSTRUCTIONS FOR THE PROGRAMMING AND ADJUSTMENT

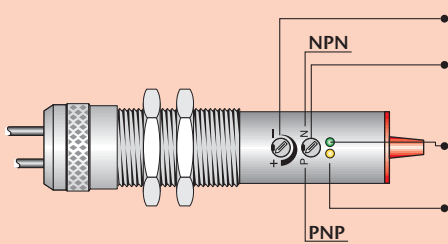

TRIMMER FOR THE SENSING RANGE ADJUSTMENT: The photocell is supplied with max. sensing range with the trimmer totally rotated in the clockwise direction. The sensitivity reduces by rotating the trimmer in the anti-clockwise direction.

SWITCH NPN/PNP: The photocell is supplied with the switch in P (PNP output). To change to NPN turn the switch to N in the anti-clockwise direction.

WARNING! For a correct working of the unit, do not carry out the switching when the photocell is powered.

GREEN LED - STABILITY INDICATOR: This led is on when the level of the output signal and the alignment of the photoelectric sensors are in the optimum position. In the case that the led is off this indicates that the lens is obscured or for the types with direct reflection a possible alteration of the dimension or color of the object to be detected.

YELLOW LED - OPERATION INDICATOR: This led is on when the object to be detected enters the sensing range of the photocell giving output signals.

N.B. SENSITIVITY ADJUSTMENT

- After adjustment the sensitivity can vary depending on variations in the object or conditions in the area of installation.
- As reflection varies in relation to the object, adjustment should be carried out with the object present.
- After having carried out adjustment, the fixing of the way and the curvature of the fiber should not be changed.

PROCEDURE FOR THE DIRECT REFLECTION FIBER OPTICS ADJUSTMENT:

Adjust the sensitivity to minimum turning the trimmer anticlockwise. Position the object to be sensed at the required distance in relation to the end of the fiber and turn the trimmer slowly clockwise until the yellow led lights up. Continue turning the trimmer until the green led lights up. Re-check that the calibration is correct by using the object and possibly by repeating the procedure.

IMPORTANT: in the presence of objects to be sensed the yellow led should be illuminated.

Output functions in the absence of the objects to be sensed.

NO output = black wire (H version = PIN 4)

NC output = white wire (H version = PIN 2)

PROCEDURE FOR THE THRU-BEAM FIBER OPTICS ADJUSTMENT:

Adjust the sensitivity to minimum turning the trimmer anticlockwise. Position the end of the fibers at the required distance and turn the trimmer slowly clockwise until the yellow led lights up. Continue turning the trimmer until the green led lights up. Re-check that the calibration is correct by using the object and possibly by repeating the procedure.

IMPORTANT: in the presence of objects to be sensed the yellow led should be illuminated.

Output functions in the absence of the objects to be sensed.

NC output = black wire (H version = PIN 4)

NO output = white wire (H version = PIN 2)

PROCEDURE FOR ASSEMBLING FIBERS IN THE FT18M-CFR

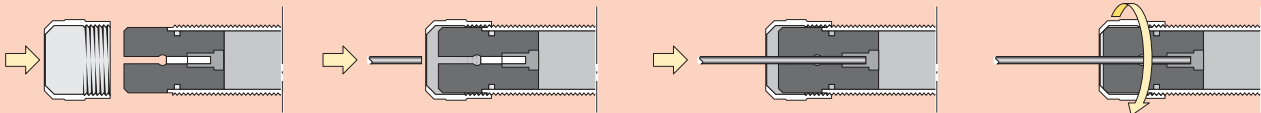

1) Position and screw the locknut in the sensor loosely.

2) With the locknut loose insert the fibers in the two receptacles.

3) With the locknut loose in the fibers ensuring that they reach the end.

4) Tighten the locknut carefully and ensure that, at the end of the operation, the fibers are blocked.

ACCESSORIES FOR MOUNTING AND INSTALLATION

MOUNTING BRACKET TYPE ST18

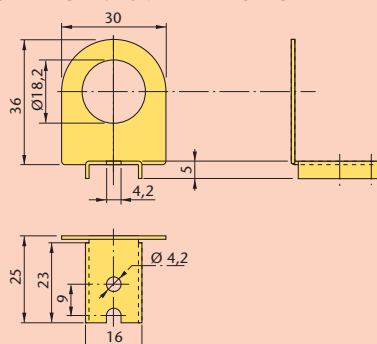

APPLICATION EXAMPLES WITH TYPE ST18

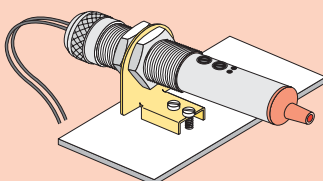

MOUNTING BRACKET TYPE ST3 FOR DIN RAIL MOUNTING

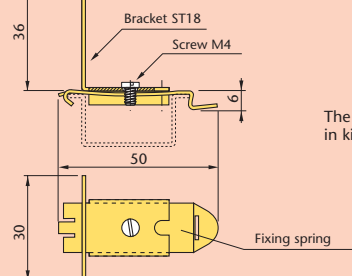

The mounting bracket ST3 is supplied in kit with ST18 + screw M4 + fixing spring.

APPLICATION EXAMPLES WITH TYPE ST3

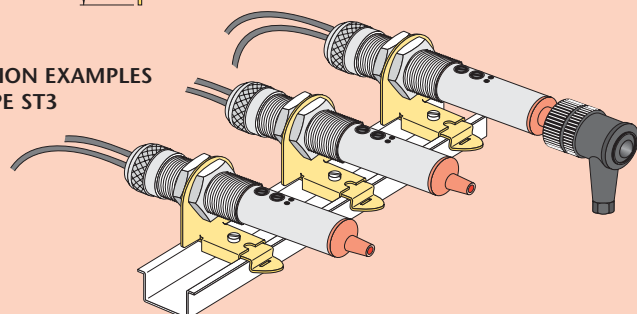

FIBER OPTIC SENSORS - NOTES AND CAUTIONS FOR CORRECT OPERATIONS



FIBER CUTTER AT 118

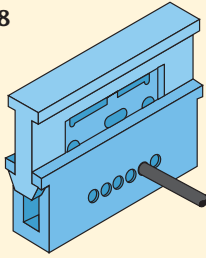

FIBER PROBES

Cutting-free type plastic fibers can be cut by the optional cutter (AT118) at any desired length

Cut the plastic fiber before connection. Make sure to cut it sharply since the status of cutting surface influences to the sensing distance which might be reduced by up to 20%.

Cutting should be done sharply by one action, and do not use the same hole more than once.

FIBER FIXING

Use the supplied spring lockwasher for fixing the fibers with threaded bushing in order not to damage the fibers with excessive force.

When fixing the non-threaded head type with a set-screw (M3 max.) as indicated on the left side scheme, apply a torque of 3 kgf/cm max.

CONNECTION OF DIRECT REFLECTION MULTI-CORED FIBER

Put the SINGLE-CORED fiber to the LIGHT-EMITTER side and the MULTI-CORED fiber to the RECEIVER side.

STAINLESS SLEEVE FIBERS

The fibers with this type of terminal are very useful when the installation is done in locations not easily accessible and this can be obtained bending the sleeve in relation to the required position.

Make the bending radius to be processed on anneals stainless sleeve on the sensing head as large as possible according to the sleeve diameter rate as indicated on the left side scheme.

TYPE	FIXING TORQUE
M 3	6 Kgf - cm MAX.
M 4	6 Kgf - cm MAX.
M 6	10 Kgf - cm MAX.

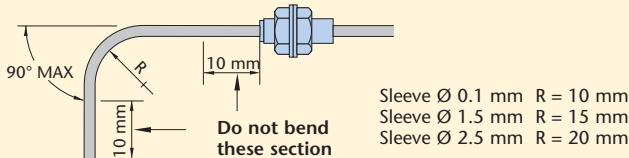
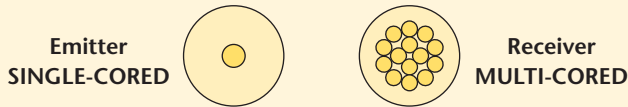
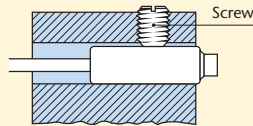

FIBER OPTIC - CHARACTERISTIC CURVES

TYPES FTL000 - FTL100 - FTL 300 (Thru beam)

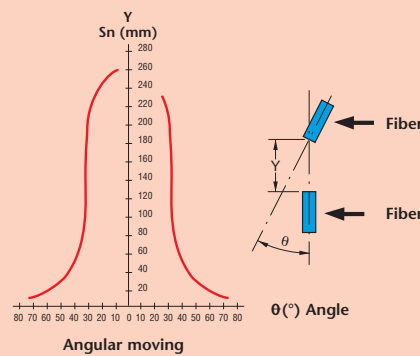
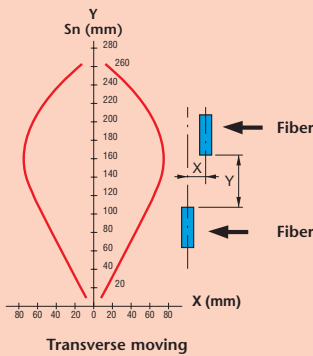

TYPES FDL 020 (Direct reflection)

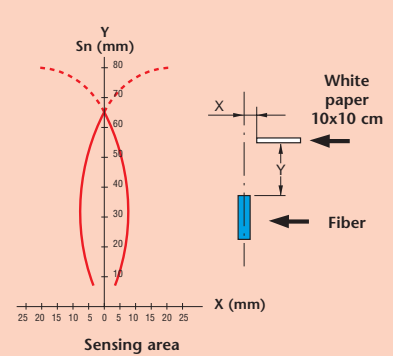

TYPES FDL010 - FDL310 (Direct reflection)

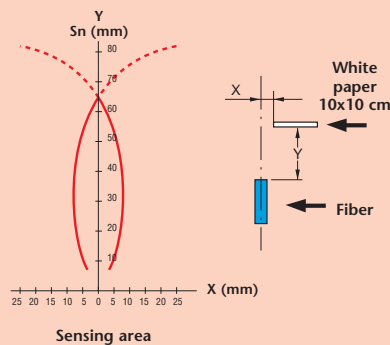

TYPES FDL311 (Direct reflection)

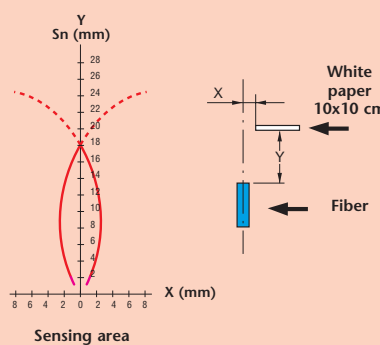

TYPES FDL210 - FDL120 (Direct reflection)

